

RAIL TIE SPACING 24"

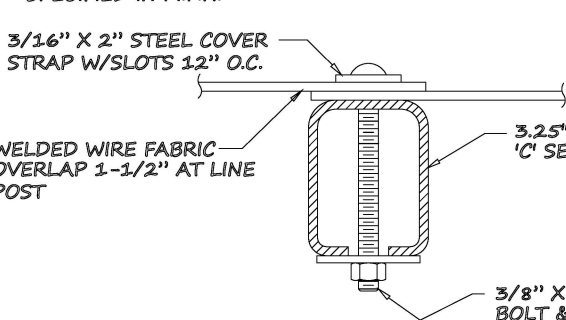
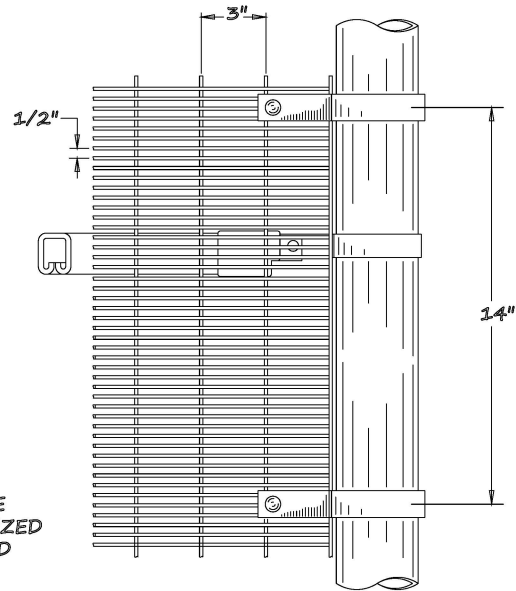
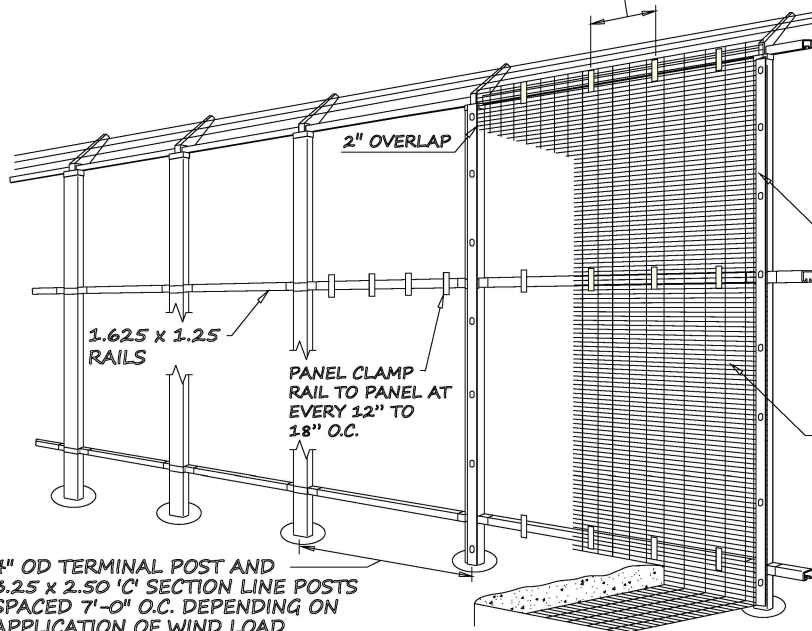

10" x 36" ANTI-DIG GRID
1/2" x 2" x 10 1/2 GA. PCV COATED
OR 18" BURIED VERTICAL

ITEM		QNTY	DESCRIPTION		MATERIAL
			MACHINING TOLERANCES		FABRICATION TOLERANCES
SCALE	NONE	CHK'D BY	DTM	0.1 ± 0.030	UNDER 18" ± 1/32
				0.02 ± 0.015	18" AND OVER ± 1/16
				0.005 ± 1/48	ALL MACHINED SURFACES 1/2
				ANGLES ± 1/48	BREAK ALL SHARP EDGES
DWN BY DTM 01-01-17 APP'D BY SUPER 'C' with BARB WIRE, ROUND TERM. COVER STRAPS (WELDED WIRE)					
CAD FILENAME: FENCE 4-11			 GREGORY FENCE 4300 13th Street SW Canton, Ohio 44710		
LAST PLOT DATE: 09/01/17					
			REF. No. DRWG No.		FENCE 4-11