

**COATINGS:**  
 FRAMEWORK-COATED PER (ASTM-F-1043) TYPE A  
 WELDED FABRIC-COMBINATION 1/2" x 2" - 2" x 2" G.A.W.  
 OR PVC COATED.

OTHER FABRIC COMBINATIONS AVAILABLE  
 FITTINGS-GALVANIZED PER (ASTM-A153)  
 TOP RAIL=263 LBS @ MID POINT OF 10'-0" SPAN

**PHYSICAL PROPERTIES:**

DIMENSIONS	WALL THICKNESS	WEIGHT PER FOOT	SECTION MODULUS	YIELD STRENGTH	MAX. BENDING MOMENT LB. IN.
3.25" x 2.50"	0.150"	5.30#	1.25	60,000	75,000
<b>OPTIONAL</b> 3.25" x 2.50"	0.130"	4.50#	1.083	60,000	64,980

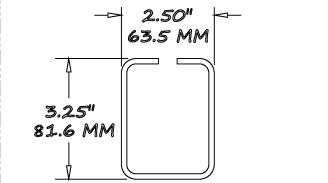
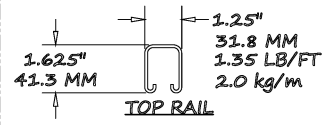
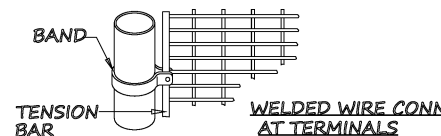
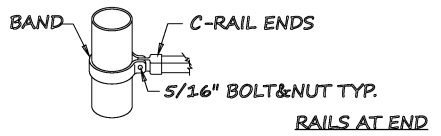
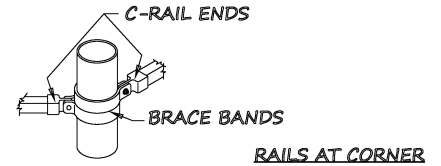
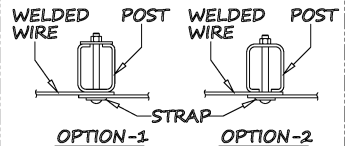
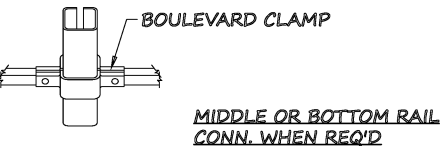

5.30 LB/FT  
7.85 kg/m  
 OPTIONAL 4.40 LB/FT  
0.130 WALL 6.52 kg/m

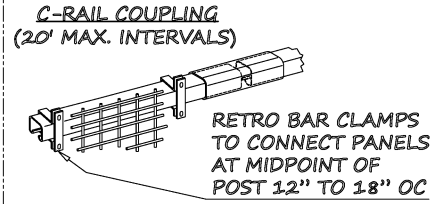
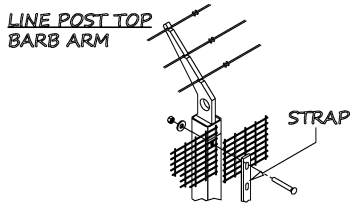
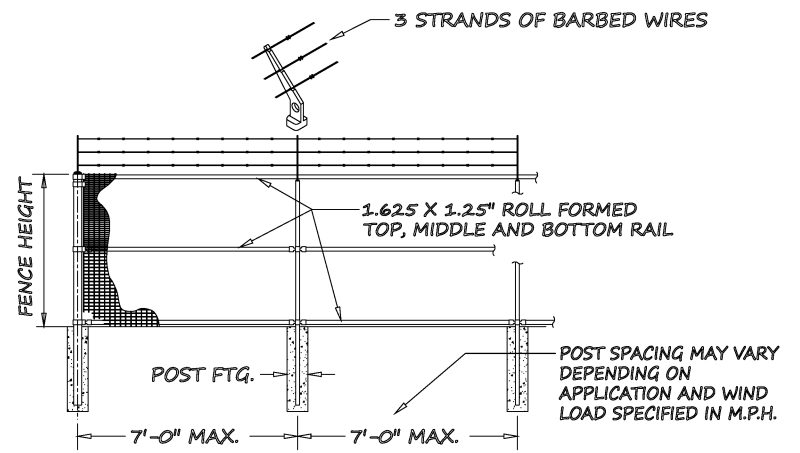
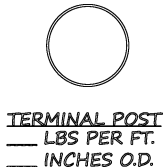

ITEM	QNTY	DESCRIPTION	MACHINING TOLERANCES	FABRICATION TOLERANCES
SCALE	NONE	CHK'D BY DTM	0.1 ± 0.030	UNDER 18" ± 1/32
DWN BY	DTM 08/17/17	APP'D BY	0.01 ± 0.015	18" AND OVER ± 1/16
			0.0015 ± 0.005	ALL MACHINED SURFACES ± 1/16
			ANGLES ± 1/48	BREAK ALL SHARP EDGES

SUPER 'C' with BARB WIRE, ROUND TERM. (WELDED WIRE)

CAD FILENAME:  
 FENCE 4-8  
 LAST PLOT DATE:  
 08/17/17

**GREGORY**  
 FENCE  
 4100 13th Street SW  
 Canton, Ohio 44710

REF. No.  
 DRWG No.  
 FENCE 4-8