

Gauge and Depth

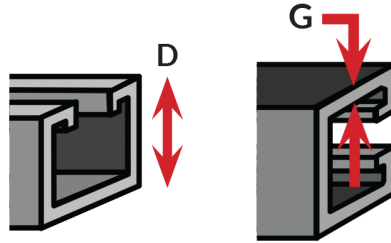

12 GAUGE 0.102
1-5/8" x 1" D

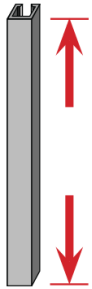



Length





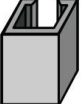



- **STANDARD 10'** (Shorter runs for easy handling)
- **STANDARD 20'** (Typical for longer runs)
- **6'8"** (Typical for commercial joists distance)
- **CUSTOM CUT-TO-LENGTH**

Perforation

	OVAL SLOT (Half slot) [9/16" x 1 1/8" x 2" on ctr.]
	LONG SLOT (Elongated slot) [13/32" x 3" x 4" on ctr.]
	ROUND HOLE [9/16" DIAM x 1-7/8" on ctr.]
	KNOCK OUT [7/8" DIAM x 6" on ctr.]
	CONTINUOUS CONCRETE INSERT
	SOLID (No perforation)

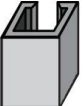
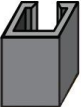
Material	
	STEEL (Carbon steel, structural grade, 33,000 min yield)
	STAINLESS STEEL [304 or 316]
	ALUMINUM
	FIBERGLASS

Finish	
	PRE-GALVANIZED (Continuous galvanized) - G90 zinc coating weight for cost-effective long-term galvanic and barrier corrosion protection
	HOT DIPPED Galvanized (HDG - after fabrication, batch dip) where aqueous or exterior applications require greater corrosion protection
	GREEN Powder or "e"-coated painted topical coating
	PVC COAT Heavy PVC coat for extended barrier protection or cosmetic effects (May PVC coat over plain or galvanized)
	WIZCoat™ GALVANNEAL Paintable pregalvanized material requires no pre-treatment. Easily spray painted post-installation
	PLAIN Untreated, "plain" steel with no topical/barrier coating
	GOLD Yellow zinc dichromate electro-galvanized
	CUSTOM COLORS Custom powder coating available in virtually any color variations



Gregory G-STRUT Submittal Form

Project Name	
Project Start Date	
Architect or Engineer	
Phone	
Contractor(s)	
Address	
City	
State	
Zip	

Approval



G102 SERIES METAL FRAMING STRUT CHANNEL

1-5/8" x 1" (1.625" x 1.00") • 12 gauge (0.102" thick)

	G102OS [Oval-Slot] 9/16" x 1-1/8" - 2" ON CTR		G102A [Back-to-Back] WELDED
	G102LS [Long-Slot] 13/32" x 3" - 4" ON CTR		G102AOS [Back-to-Back Oval-Slot] WELDED
	G102H [Holes] 9/16" DIAM. - 1-7/8" ON CTR		G102KO [KNOCK OUT] 7/8" DIAM. - 6" ON CTR

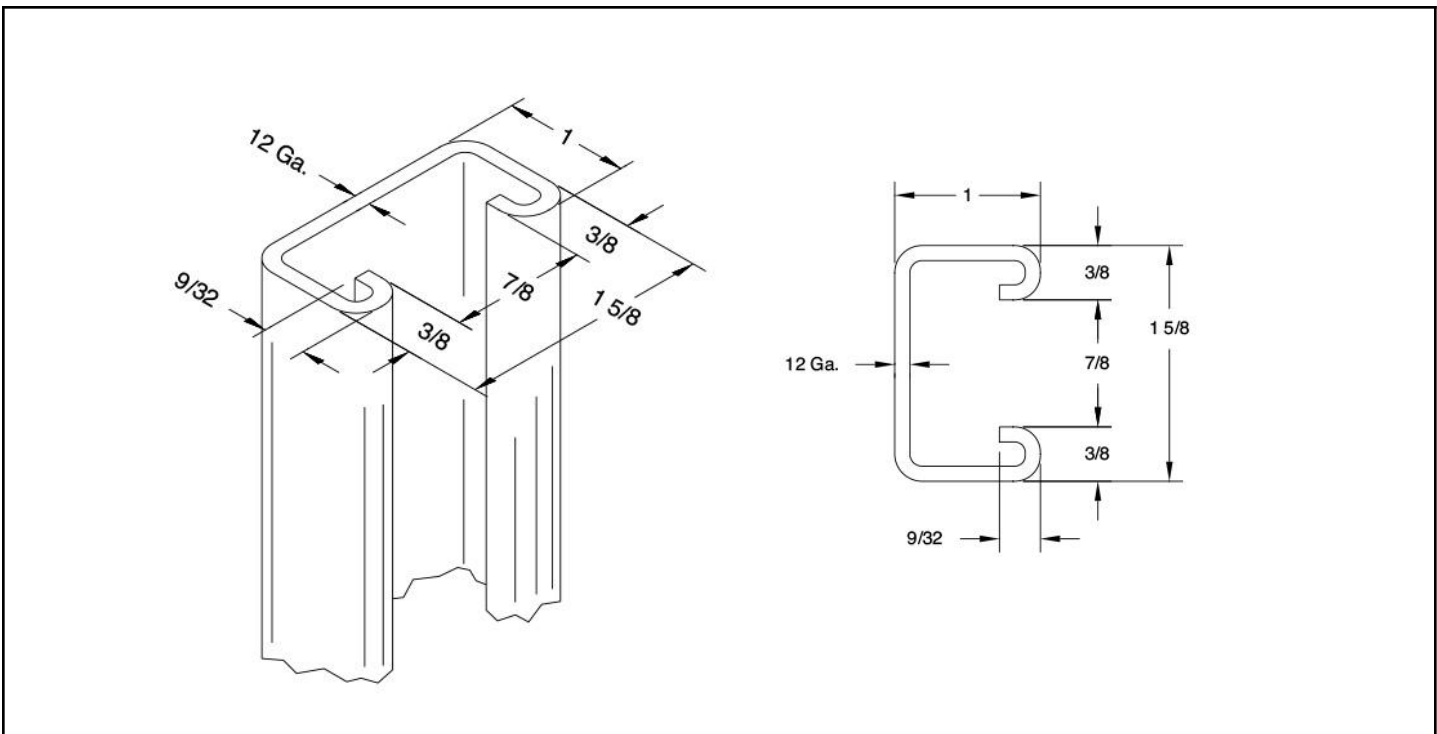

ITEM	QNT'Y	DESCRIPTION	MATERIAL
		ROLLFORM TOLERANCES	
SCALE	FULL	CHK'D BY	LENGTH ± 0.125"
DWN BY	IDI	02-02-02	APP'D BY
ALL OTHER DIMENSIONS ± 0.020"			

G-STRUT CHANNEL, PART # G102

CAD FILENAME G102	GREGORY STRUT PRODUCTS Division of Gregory Industries 4100 13th Street SW, Canton, OH 44710 PH: 330-477-4800 • FX: 330-477-0626	REF. No.
LAST PLOT DATE 02-02-02		DRWG No. G102

This drawing is the property of Gregory Strut Prod. and is loaned without other consideration than the agreement and condition that it is not to be reproduced, copied or otherwise disposed of, directly or indirectly, and is not to be used in whole or in part to assist in making or to furnish any information for the making of drawings, prints apparatus or parts thereof. This drawing shall be returned to Gregory Strut Prod. upon request. The acceptance of this drawing will be construed as an acceptance of the foregoing conditions, and as an admission of the exclusive ownership in and to the drawing of Gregory Strut products.



G102 SERIES METAL FRAMING STRUT CHANNEL

ELEMENTS OF SECTION								
			X-X AXIS			Y-Y AXIS		
Strut Section No.	Weight/ Foot lbs.	Area of Section in. ²	Moment of Inertia in. ⁴	Section Modulus in. ³	Radius of Gyration in.	Moment of Inertia in. ⁴	Section Modulus in. ³	Radius of Gyration in.
G102	1.395	0.41	0.051	0.087	0.353	0.156	0.192	0.617
G102A	2.79	0.82	0.241	0.241	0.542	0.312	0.384	0.617

BEAM & COLUMN LOADS					
Strut Section Number	Beam Span or Column Height	Maximum Column Load	Total Uniform Load @25,000 psi	Deflection @ 25,000 psi	Uniform Load @ 1/240 Span Deflection
	in.	lbs.	lbs.	in.	lbs.
G102	12	7530	1450	0.02	-
	18	7060	960	0.04	-
	24	6520	720	0.08	-
	30	5910	580	0.13	520
	36	5220	480	0.19	360
	42	4460	410	0.26	260
	48	3630	360	0.35	200
	54	2870	320	0.44	160
	60	2320	290	0.55	130
	66	1920	260	0.65	100
	72	1610	240	0.78	90
	84	-	200	1.04	60
	96	-	180	1.4	50
	108	-	160	1.77	40
	120	-	140	2.12	30
	132	-	130	2.63	20
	144	-	120	3.15	20
	156	-	110	3.67	10
	168	-	100	4.17	10
	180	-	90	4.62	10
	192	-	90	5.6	10
	204	-	80	5.97	10
	216	-	80	7.09	10
	228	-	70	7.3	0
	240	-	70	8.51	0



G102 SERIES METAL FRAMING STRUT CHANNEL

BEAM & COLUMN LOADS					
Strut Section Number	Beam Span or Column Height	Maximum Column Load	Total Uniform Load @25,000 psi	Deflection @ 25,000 psi	Uniform Load @ 1/240 Span Deflection
	in.	lbs.	lbs.	in.	lbs.
G102A	12	15760	4010	0.01	-
	18	15360	2670	0.02	-
	24	14900	2000	0.05	-
	30	14400	1600	0.08	-
	36	13840	1330	0.11	-
	42	13240	1140	0.15	-
	48	12600	1000	0.2	-
	54	11910	890	0.26	760
	60	11190	800	0.32	620
	66	10420	730	0.39	510
	72	9600	660	0.45	430
	84	7850	570	0.62	310
	96	6060	500	0.82	240
	108	4790	440	1.03	190
	120	3880	400	1.28	150
	132	3210	360	1.54	120
	144	-	330	1.83	100
	156	-	300	2.12	90
	168	-	280	2.47	70
	180	-	260	2.82	60
	192	-	250	3.29	60
	204	-	230	3.63	50
	216	-	220	4.13	40
	228	-	210	4.63	40
	240	-	200	5.15	30

For Perforated Channels, Reduce Total Beam Load Values as Follows:

G102/G102A	OS	22%
G102/G102A	LS	35%
G102/G102A	H	13%
G102/G102A	KO	6%

E = 29000; Fy = 42700; K = 0.8



G102 SERIES METAL FRAMING STRUT CHANNEL

COLUMN LOADS: Column loads are for allowable axial loads for the unsupported heights listed (including a K value of 0.80). Column loads must be reduced for eccentric loading.

BEAM LOADS: Loads listed are distributed uniformly. For loads concentrated at center of span, multiply uniform load by 0.5 and deflection by 0.8. Where deflection is not a factor, use stress of 25,000 PSI. When deflection is a factor, use deflection of 1/240 span.