

Gauge and Depth

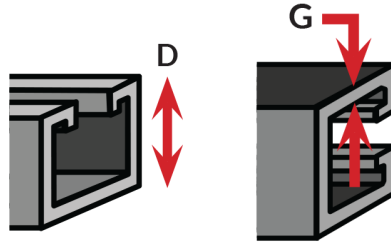

12 GAUGE 0.102
1-5/8" x 1-3/8" D

Length

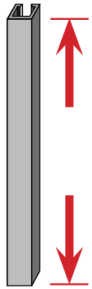





- **STANDARD 10'** (Shorter runs for easy handling)
- **STANDARD 20'** (Typical for longer runs)
- **6'8"** (Typical for commercial joists distance)
- **CUSTOM CUT-TO-LENGTH**



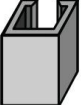





Perforation

	OVAL SLOT (Half slot) [9/16" x 11/8" x 2" on ctr.]
	LONG SLOT (Elongated slot) [13/32" x 3" x 4" on ctr.]
	ROUND HOLE [9/16" DIAM x 1-7/8" on ctr.]
	KNOCK OUT [7/8" DIAM x 6" on ctr.]
	CONTINUOUS CONCRETE INSERT
	SOLID (No perforation)

Material

	STEEL (Carbon steel, structural grade, 33,000 min yield)
	STAINLESS STEEL [304 or 316]
	ALUMINUM
	FIBERGLASS

Finish

	PRE-GALVANIZED (Continuous galvanized) - G90 zinc coating weight for cost-effective long-term galvanic and barrier corrosion protection
	HOT DIPPED Galvanized (HDG - after fabrication, batch dip) where aqueous or exterior applications require greater corrosion protection
	GREEN Powder or "e"-coated painted topical coating
	PVC COAT Heavy PVC coat for extended barrier protection or cosmetic effects (May PVC coat over plain or galvanized)
	WIZCoat™ GALVANNEAL Paintable pregalvanized material requires no pre-treatment. Easily spray painted post-installation
	PLAIN Untreated, "plain" steel with no topical/barrier coating
	GOLD Yellow zinc dichromate electro-galvanized
	CUSTOM COLORS Custom powder coating available in virtually any color variations



Gregory G-STRUT Submittal Form

Project Name	
Project Start Date	
Architect or Engineer	
Phone	
Contractor(s)	
Address	
City	
State	
Zip	

Approval



G382 SERIES METAL FRAMING STRUT CHANNEL

1-5/8" x 1-3/8" (1.625" x 1.375") • 12 gauge (0.102" thick)

	G382OS [Oval-Slot] 9/16" x 1-1/8" - 2" ON CTR		G382A [Back-to-Back] WELDED
	G382LS [Long-Slot] 13/32" x 3" - 4" ON CTR		G382AOS [Back-to-Back Oval-Slot] WELDED
	G382H [Holes] 9/16" DIAM. - 1-7/8" ON CTR		G382KO [KNOCK OUT] 7/8" DIAM. - 6" ON CTR

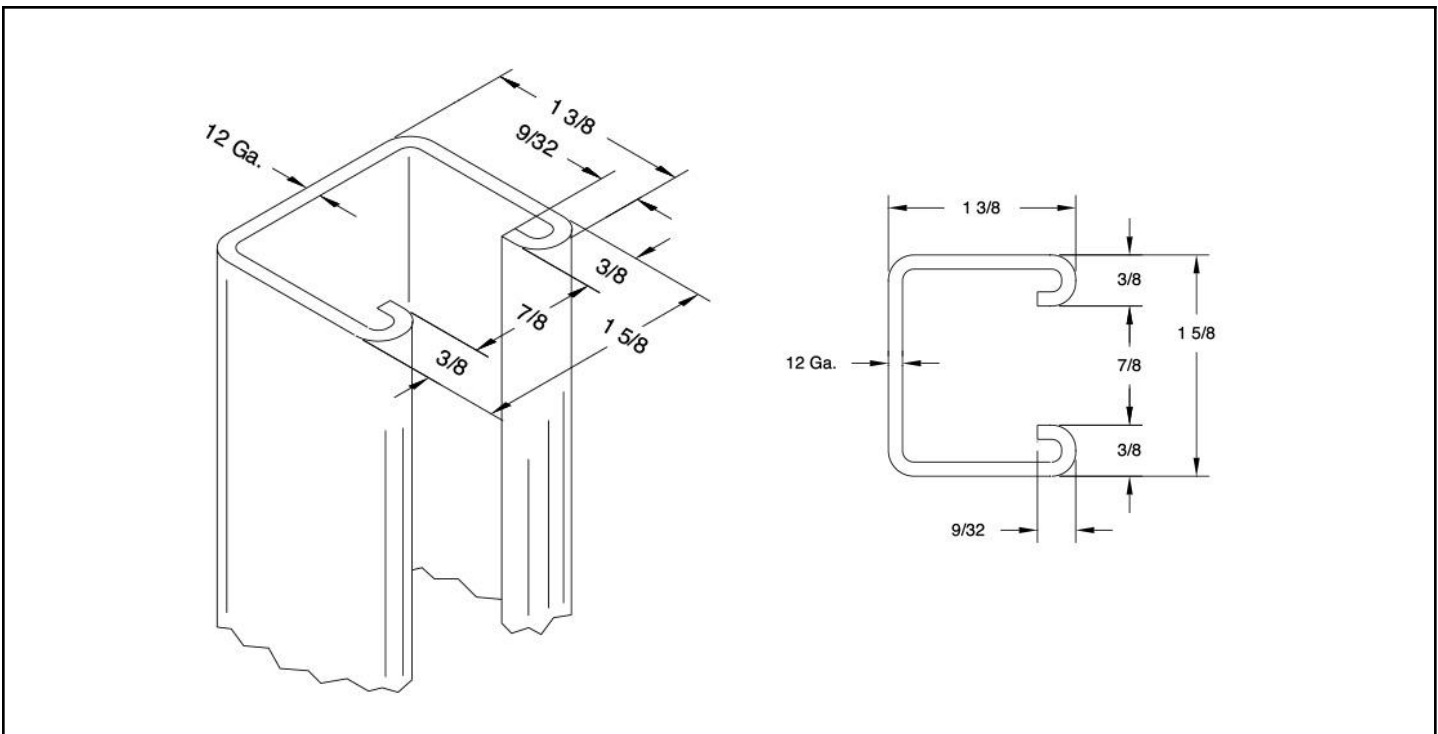

ITEM	QNT'Y	DESCRIPTION	MATERIAL
			ROLLFORM TOLERANCES
SCALE	FULL	CHK'D BY	LENGTH ± 0.125"
DWN BY	IDI	02-02-02	APP'D BY
ALL OTHER DIMENSIONS ± 0.020"			

G-STRUT CHANNEL, PART # G382

CAD FILENAME G382	GREGORY STRUT PRODUCTS Division of GRegory Industries 4100 13th Street SW, Canton, OH 44710 PH: 330-477-4800 • FX: 330-477-0626	REF. No.
LAST PLOT DATE 02-02-02		DRWG No. G382

This drawing is the property of Gregory Strut Prod. and is loaned without other consideration than the agreement and condition that it is not to be reproduced, copied or otherwise disposed of, directly or indirectly, and is not to be used in whole or in part to assist in making or to furnish any information for the making of drawings, prints apparatus or parts thereof. This drawing shall be returned to Gregory Strut Prod. upon request. The acceptance of this drawing will be construed as an acceptance of the foregoing conditions, and as an admission of the exclusive ownership in and to the drawing of Gregory Strut products.



G382 SERIES METAL FRAMING STRUT CHANNEL

ELEMENTS OF SECTION								
			X-X AXIS			Y-Y AXIS		
Strut Section No.	Weight/ Foot lbs.	Area of Section in. ²	Moment of Inertia in. ⁴	Section Modulus in. ³	Radius of Gyration in.	Moment of Inertia in. ⁴	Section Modulus in. ³	Radius of Gyration in.
G382	1.654	0.486	0.116	0.147	0.489	0.2	0.246	0.642
G382A	3.308	0.972	0.567	0.412	0.764	0.4	0.492	0.642

BEAM & COLUMN LOADS					
Strut Section Number	Beam Span or Column Height	Maximum Column Load	Total Uniform Load @25,000 psi	Deflection @ 25,000 psi	Uniform Load @ 1/240 Span Deflection
	in.	lbs.	lbs.	in.	lbs.
G382	12	9620	2450	0.01	-
	18	9250	1630	0.03	-
	24	8820	1220	0.06	-
	30	8340	980	0.1	-
	36	7820	810	0.14	-
	42	7250	700	0.2	610
	48	6630	610	0.26	460
	54	5970	540	0.32	360
	60	5260	490	0.4	290
	66	4490	440	0.48	240
	72	3780	400	0.57	200
	84	2770	350	0.8	150
	96	2120	300	1.02	110
	108	1680	270	1.31	90
	120	-	240	1.6	70
	132	-	220	1.95	60
	144	-	200	2.31	50
	156	-	180	2.64	40
	168	-	170	3.12	30
	180	-	160	3.61	30
	192	-	150	4.1	20
	204	-	140	4.6	20
	216	-	130	5.07	20
	228	-	120	5.5	20
	240	-	120	6.42	10



G382 SERIES METAL FRAMING STRUT CHANNEL

BEAM & COLUMN LOADS					
Strut Section Number	Beam Span or Column Height	Maximum Column Load	Total Uniform Load @25,000 psi	Deflection @ 25,000 psi	Uniform Load @ 1/240 Span Deflection
	in.	lbs.	lbs.	in.	lbs.
G382A	12	19800	6860	0	-
	18	19480	4570	0.02	-
	24	19110	3430	0.03	-
	30	18710	2740	0.05	-
	36	18280	2280	0.08	-
	42	17810	1960	0.11	-
	48	17310	1710	0.14	-
	54	16790	1520	0.18	-
	60	16230	1370	0.23	-
	66	15650	1240	0.28	1200
	72	15040	1140	0.33	1010
	84	12820	980	0.45	740
	96	10140	850	0.59	570
	108	8010	760	0.75	450
	120	6490	680	0.93	360
	132	5360	620	1.12	300
	144	4500	570	1.34	250
	156	3840	520	1.56	210
	168	-	490	1.83	180
	180	-	450	2.07	160
	192	-	420	2.35	140
	204	-	400	2.68	120
	216	-	380	3.03	110
	228	-	360	3.37	100
	240	-	340	3.72	90

For Perforated Channels, Reduce Total Beam Load Values as Follows:

G382/G382A	OS	21%
G382/G382A	LS	34%
G382/G382A	H	13%
G382/G382A	KO	6%

E = 29000; Fy = 42700; K = 0.8



G382 SERIES METAL FRAMING STRUT CHANNEL

COLUMN LOADS: Column loads are for allowable axial loads for the unsupported heights listed (including a K value of 0.80). Column loads must be reduced for eccentric loading.

BEAM LOADS: Loads listed are distributed uniformly. For loads concentrated at center of span, multiply uniform load by 0.5 and deflection by 0.8. Where deflection is not a factor, use stress of 25,000 PSI. When deflection is a factor, use deflection of 1/240 span.