

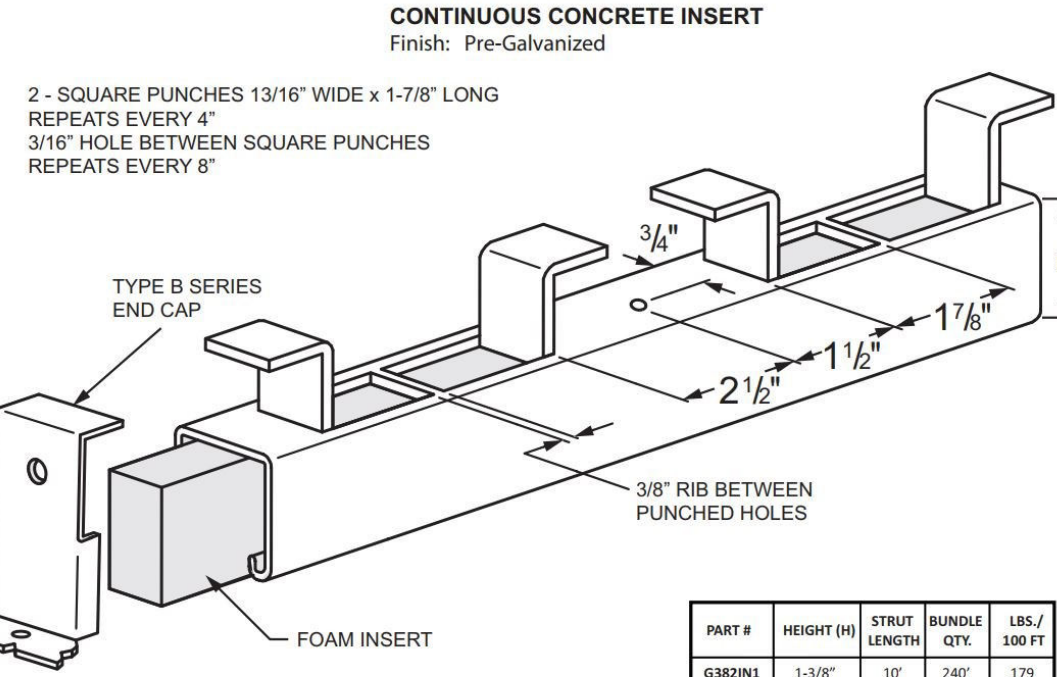

G-STRUT 4100 13th Street SW, Canton OH 44710
 Phone: 866.997.8788 – Fax: 330.477.0626
www.gregorystrut.com

GSPCI, GSS, G382, G134, G582
 Concrete Insert Fittings

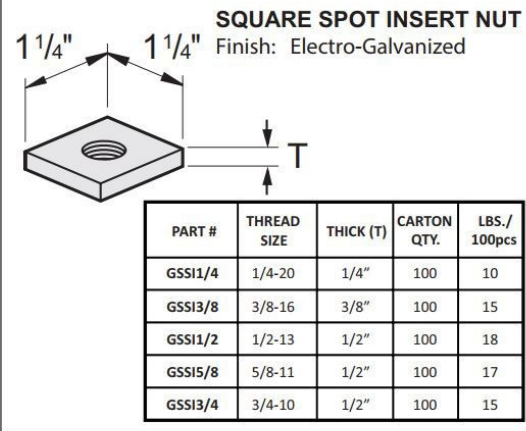
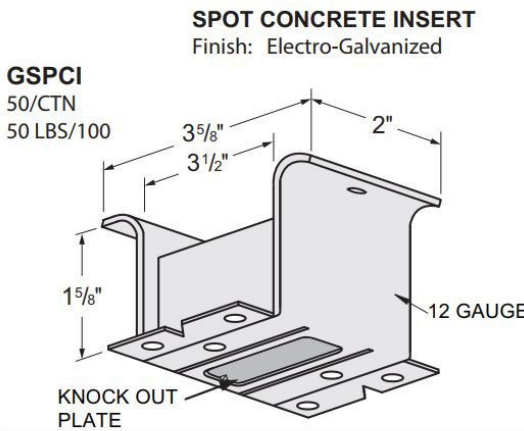

PROJECT INFORMATION	APPROVAL STAMP
Project:	Notes:
Address:	
Contractor:	
Engineer:	
Date:	
Approved <input type="checkbox"/> Approved as Noted <input type="checkbox"/> Not Approved <input type="checkbox"/>	