

**RAIL TIE SPACING 24"**

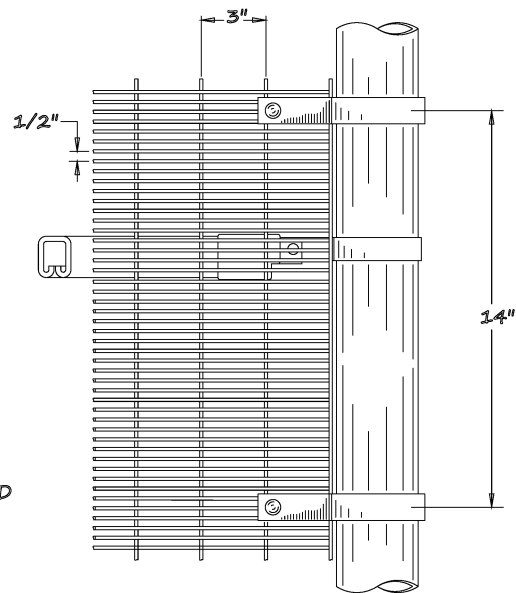

**END/CORNER CONNECTION**

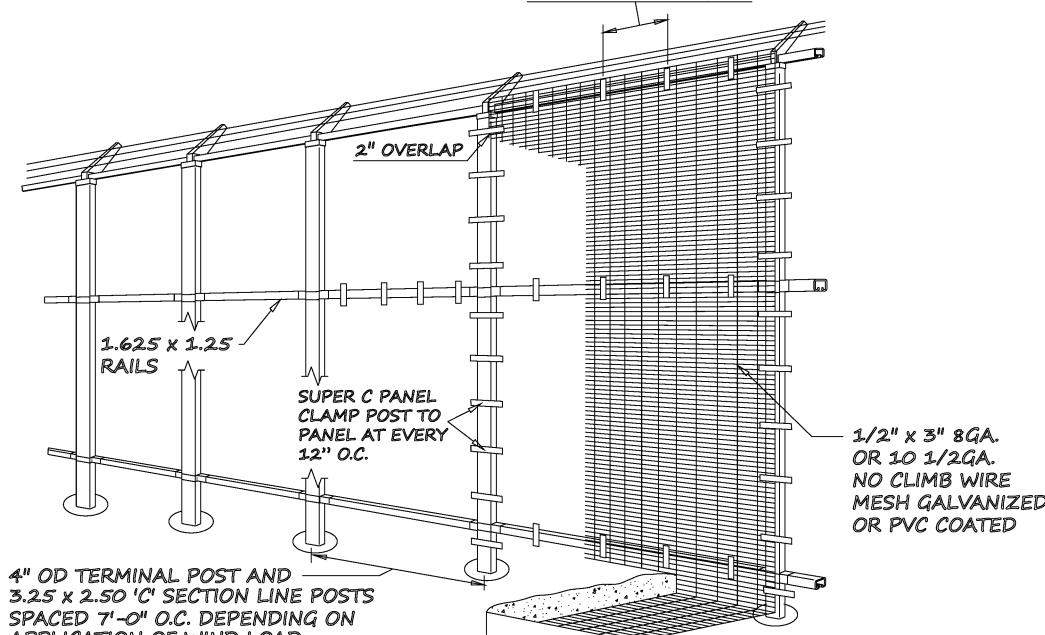
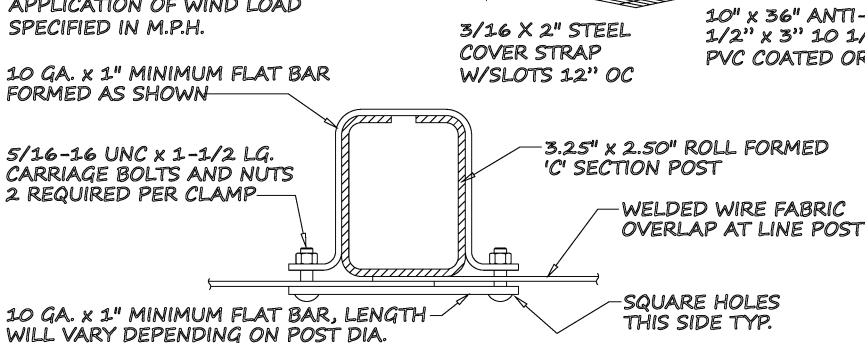

ITEM	QNTY	DESCRIPTION		MATERIAL
SCALE	NONE	CHK'D BY	DTM	MACHINING TOLERANCES 0.1 ± 0.030 0.05 ± 0.015
DWN BY	DTM	01-01-17	APP'D BY	FABRICATION TOLERANCES UNDER 18" ± 1/32 18" AND OVER ± 1/16
				ALL MACHINED SURFACES 1/2° BREAK ALL SHARP EDGES

**SUPER 'C' with BARB WIRE, ROUND TERM. PANEL CLAMPS (WELDED WIRE)**

CAD FILENAME:  
FENCE 4-12  
LAST PLOT DATE:  
09/01/17

**GREGORY**  
FENCE  
4100 13th Street SW  
Canton, Ohio 44710

REF. No.  
DRWG No.  
**FENCE 4-12**