

COATINGS:
 FRAMEWORK-COATED PER (ASTM-F-1043) TYPE A
 EXPANDED METAL PANELS 4' OR 5' WIDE X FENCE HEIGHT
 1"-7 OR 3/4"-9 REVERSED DIAMOND
 FITTINGS-GALVANIZED PER (ASTM-A153)
 TOP RAIL=263 LBS @ MID POINT OF 10'-0" SPAN

PHYSICAL PROPERTIES:

DIMENSIONS	WALL THICKNESS	WEIGHT PER FOOT	SECTION MODULUS	YIELD STRENGTH	MAX. BENDING MOMENT LB. IN.
3.25" x 2.50"	0.130"	4.50#	1.25	60,000	75,000
DIMENSIONS	WALL THICKNESS	WEIGHT PER FOOT	SECTION MODULUS	YIELD STRENGTH	MAX. BENDING MOMENT LB. IN.
3.25" x 2.50"	0.150"	5.40#	1.25	60,000	75,000

RETRO BAR CLAMPS TO CONNECT PANELS AT MIDPOINT OF POST 12" TO 18" OC



3 STRANDS OF BARBED WIRES

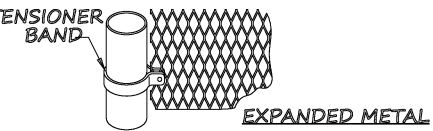
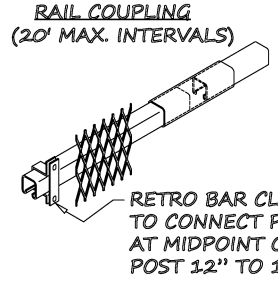
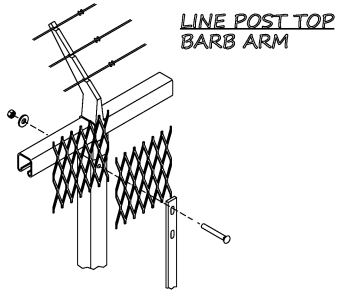
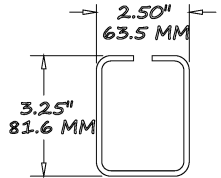
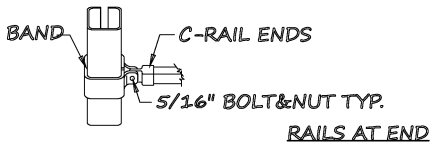
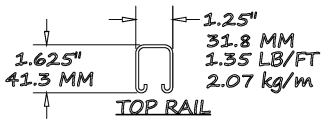
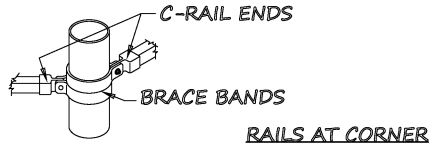
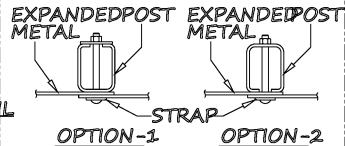
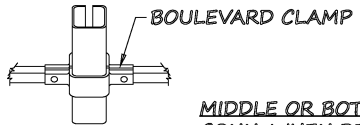
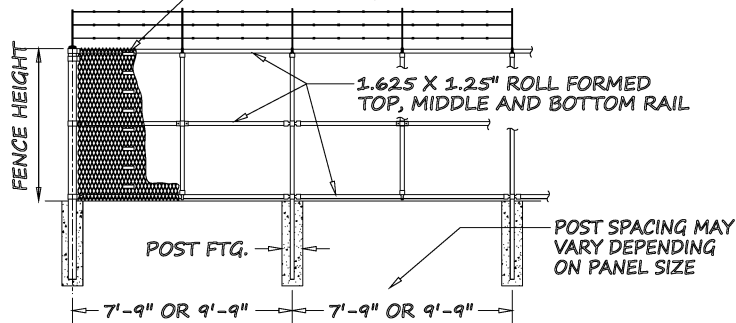

TERMINAL POST
 9.11 LBS PER FT.
 4" INCHES O.D.

ITEM	QNTY	DESCRIPTION		MATERIAL
SCALE	NONE	CHK'D BY	DTM	MACHINING TOLERANCES: UNDER 18" ± 1/32 18" AND OVER ± 1/16 ALL MACHINED SURFACES ± .001 ANGLES ± 1/48
DWN BY	DTM 10-17-17	APP'D BY		FABRICATION TOLERANCES: ± 1/32 ± 1/16 ± 1/8 ± 1/4

SUPER 'C' - with BARB WIRE, ROUND TERM. (EXPANDED METAL)

CAD FILENAME:
 FENCE 4-4
 LAST PLOT DATE:
 10/17/17

GREGORY
 FENCE
 4100 13th Street SW
 Canton, Ohio 44710

REF. No.
 DRWG No.
 FENCE 4-4