

**COATINGS:**

FRAMEWORK-COATED PER (ASTM-F-1043) TYPE A  
 WELDED FABRIC-NO CUT/NO CLIMB 1/2" x 3" G.A.W.  
 OR PVC COATED.  
 OTHER FABRIC COMBINATIONS AVAILABLE  
 FITTINGS-GALVANIZED PER (ASTM-A153)  
 TOP RAIL=263 LBS @ MID POINT OF 10'-0" SPAN

**PHYSICAL PROPERTIES:**

DIMENSIONS	WALL THICKNESS	WEIGHT PER FOOT	SECTION MODULUS	YIELD STRENGTH	MAX. BENDING MOMENT LB. IN.
3.25" x 2.50"	0.150"	5.40#	1.25	60,000	75,000
OPTIONAL					
3.25" x 2.50"	0.130"	4.50#	1.083	60,000	64,980

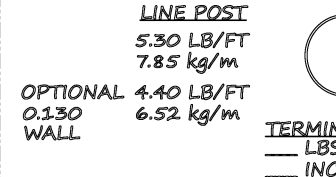
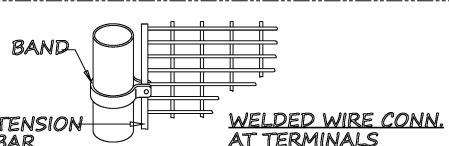
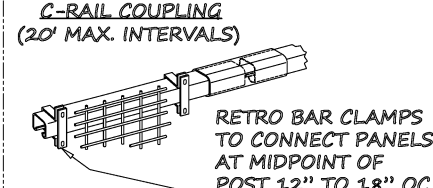
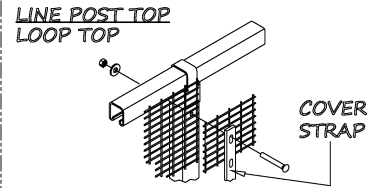
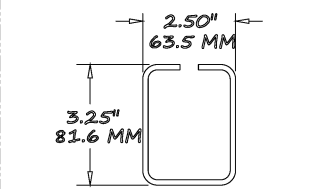
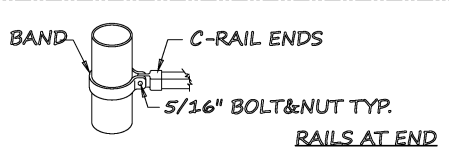
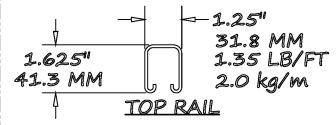
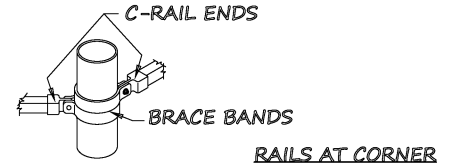
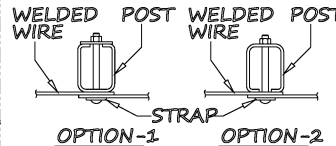
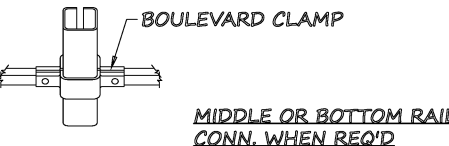
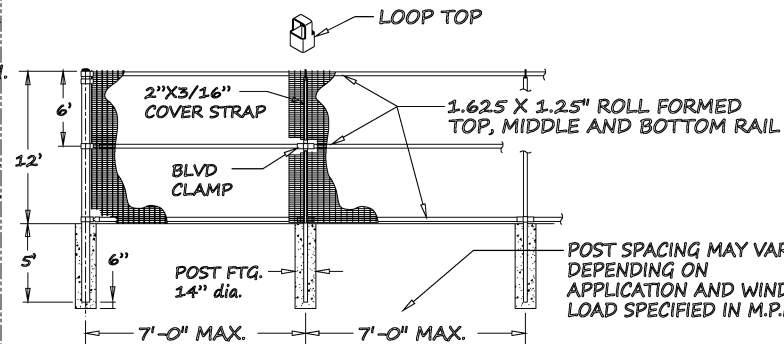

ITEM	QNTY	DESCRIPTION	MATERIAL
SCALE	NONE	CHK'D BY DTM	MACHINING TOLERANCES: 0.1 ± 0.030, 0.02 ± 0.015
DWN BY	DTM08/17/17	APP'D BY	FABRICATION TOLERANCES: UNDER 18" ± 1/32, 18" AND OVER ± 1/16
			0.005 ± 0.005, ANGLES ± 1/16, ALL MACHINED SURFACES ± 1/16 BREAK ALL SHARP EDGES

SUPER 'C' w/o BARB WIRE, ROUND TERM. (WELDED WIRE)

CAD FILENAME:  
 FENCE 4-7  
 LAST PLOT DATE:  
 08/17/17

**GREGORY**  
 FENCE  
 4100 13th Street SW  
 Canton, Ohio 44710

REF. No.  
 DRWG No.  
 FENCE 4-7