



G-STRUT 4100 13th Street SW, Canton OH 44710

Phone: 866.997.8788 – Fax: 330.477.0626

www.gregorystrut.com

RETAINING STRAP – SERIES W117

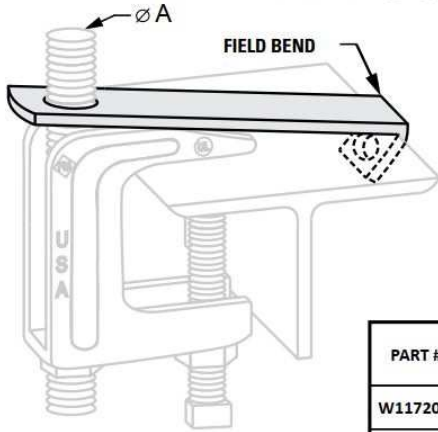

Size Range: Strap is punched with 1/2" and 3/8" hole on same strap.

Material: Low Carbon Steel

Finish: Electro-Galvanized.

Ordering: Specify rod size, length, finish and series #.

Available In: 304 & 316 Stainless Steel

All retaining straps are electro-galvanized. To order other finishes, change the 5th character in the Part # as seen below:
 STAINLESS STEEL (304) = 8
 STAINLESS STEEL (316) = 0
 Example: **W117 2 03 8** = STAINLESS STEEL

PART #	ROD SIZE (A)	MATERIAL SIZE	WEIGHT EACH (in lbs.)				
			TOTAL PRE-BENT LENGTH OF STRAP (inches)				
			4-1/2"	6"	8"	10"	14"
W117203	3/8"	14ga. x 1"	.15	.21	.28	.35	.49
W117204	1/2"	14ga. x 1"	.15	.21	.28	.35	.49
W117205	5/8"	14ga. x 1-1/4"	.20	.26	.35	.44	.62
W117206	3/4"	14ga. x 1-1/4"	.20	.26	.35	.44	.62
W117207	7/8"	14ga x 2"	.31	.42	.56	.70	.98

RETAINING STRAP – SERIES W118

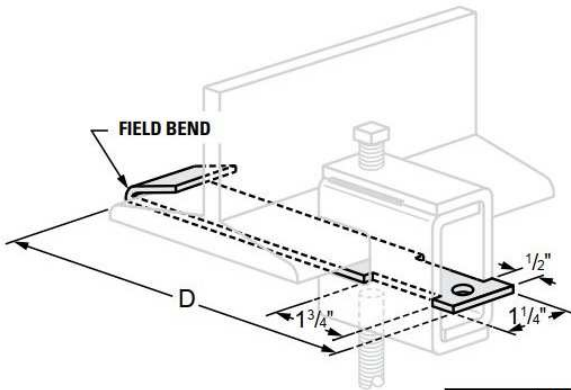

Size Range: 3/4" Max. Flange Thickness

Material: Low Carbon Steel

Finish: Electro-Galvanized.

Ordering: Specify length, flange width, finish and series #.

Function: For use with G410 and G411 Series beam clamps.

Available In: Hot Dip Galvanized

All above straps are electro-galv. To order other finishes, change the 5th character in the Part # as seen below:
 HOT DIP GALVANIZED = 9
 Example: **W118 2 60 9** = HOT DIP GALV

PART #	PRE-BENT STRAP LENGTH (D)	FLANGE WIDTH	LBS./100pcs	PART #	PRE-BENT STRAP LENGTH (D)	FLANGE WIDTH	LBS./100pcs
W118260	6"	6"	22	W1182120	12"	12"	40
W118290	9"	9"	30	W1182180	18"	15"	49

PROJECT INFORMATION	APPROVAL STAMP
Project:	Notes:
Address:	
Contractor:	
Engineer:	
Date:	
Approved <input type="checkbox"/> Approved as Noted <input type="checkbox"/> Not Approved <input type="checkbox"/>	