

G-STRUT WHITEPAPER

CONDUIT CLAMPS
PIPE STRAPS &
PIPE CLAMPS

Conduit Clamps, Tube Clamps, Pipe Hangers and Pipe Straps secure conduit, pipe, tube, pvc, electrical and cable wiring to horizontal and vertical beams/infrastructure with metal framing strut channel systems and configurations. Pipe Clamps are designed to fit securely into the standard openings of 1 5/8" strut channel.

DEFINITIONS

Conduit clamps and Pipe Straps are used to secure:

EMT

Electrical Metallic Tubing (EMT) is lightweight steel tubing. It is generally considered simple to install and may be curved/bent or cut with simple tools in the field. EMT conduit is less expensive than IMC or GRC, but the thin walls are more easily susceptible to puncture.

RMC

Rigid Metal Conduit (RMC) provides physical protection for cables and conductors. Typically hot-dip galvanized steel with a coupling on one end and a thread protector opposite. Designed for protection and routing of conductors and cables.

GRC

Galvanized Rigid Steel Conduit is the heaviest weight and thickest wall of electrical conduits.

IMC

Intermediate Metal Conduit (IMC) is galvanized steel raceway. Typically used to protect and route conductors and cables. Other applications include equipment grounding conductor when installed to code with appropriate fittings and couplings.

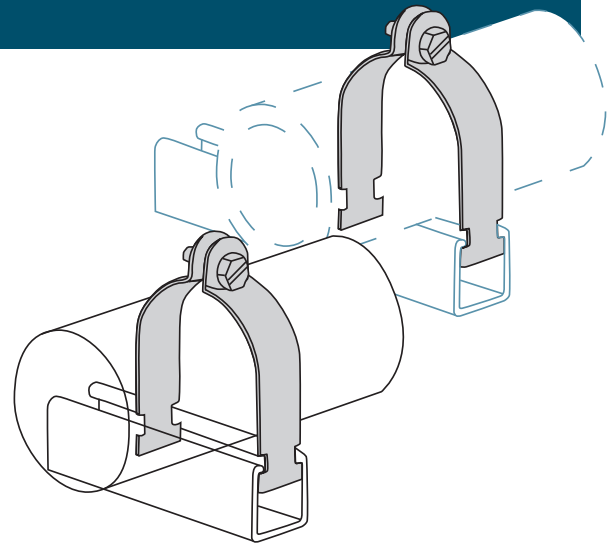

O.D.

Outside Diameter; tubing is measured by the O.D.

NPS

Nominal Pipe Size; pipe is measured by the NPS, which is a North American set of standard sizes for pipes used for high or low pressures and temperatures. "Nominal" refers to pipe in non-specific terms and identifies the diameter of the hole with a non-dimensional number (for example – 2-inch nominal steel pipe" consists of many varieties of steel pipe with the only criterion being a 2.375-inch (60.3 mm) outside diameter). Specific pipe is identified by pipe diameter and another non-dimensional number for wall thickness referred to as the Schedule (Sched. or Sch., for example – "2-inch diameter pipe, Schedule 40").

STRUT CLAMPS AND PIPE STRAPS CATEGORIES



EMT 'THINWALL' CONDUIT CLAMPS

Commonly used to secure Electrical Metallic Conduit (Type EMT), which is a thin-wall, electroplated tubing for housing electrical wiring. EMT is technically a tubing. Electricians often refer to running wire through conduit, which is referencing EMT product. EMT is thin-wall tubing; most commonly formed from steel with a galvanized protective coating. Also available in aluminum and stainless steel. Thinwall clamps are designed for lighter weight applications.



RIGID CONDUIT CLAMPS

Rigid metal conduit is a thick-walled threaded tubing, typically galvanized. Its common applications are in commercial and industrial construction. Rigid or thicker walled clamps are typically preferred for securing these heavier duty applications.



UNIVERSAL CLAMPS

Universal pipe clamps are designed for field flexibility and broader electrical and mechanical applications. Compatible with rigid or IMC conduit, pipe and EMT.



O.D. TUBING CLAMPS

O.D. Tubing is measured by the OUTSIDE DIAMETER (O.D.), with values expressed in inches. For example, a pipe size of 1 1/2" actually has an outside diameter of 1.9", not 1 1/2". For sizes up to 12", the NPS refers to the nominal inside diameter, which is something different than its actual ID. Over 12-inches, NPS refers to the actual OD.

STRUT CLAMPS AND PIPE STRAPS CATEGORIES



CUSHION CLAMPS

Used to secure tubing or pipe to strut; these steel clamps are installed with a plastic or rubber cushion between the clamp and the pipe or tube. Primarily functions are to absorb shock and vibration, reduce unwanted noise, and prevent galvanic corrosion between metals.



ONE PIECE PIPE AND CABLE CLAMP

A specialty clamp specifically designed for a quick, one-handed installation with a screw or nut driver.



RISER CLAMPS

A type of hardware used by mechanical building trades for pipe support in vertical runs of piping (risers) at each floor level. The devices are placed around the pipe and fasteners, then tightened to clamp them onto the pipe. The friction between the pipe and riser clamp transfers the weight of the pipe through the riser clamp to the building structure.



OTHER SPECIALTY CLAMPS

Other specialty clamps, variations of the above, include 1 HOLE TUBING CLAMPS, RIGHT ANGLE CLAMPS, 2-HOLE PIPE STRAPS, PARALLEL CLAMPS, CABLE CLAMPS, and EZ/1-PIECE.



UBOLT BEAM CLAMP/WINDOW CLAMP

A window clamp is a beam clamp with a U-bolt that is designed to easily fasten the strut channel to a support beam.

TYPICAL FINISHES AND MATERIALS INCLUDE:

- Electrogalvanized, hot-dipped, yellow zinc electroplate and copper plated steel
- Stainless Steel, Gr. 304 & 316
- Green powder & Black PVC coated
- Aluminum
- Fiberglass

TESTING PARAMETERS FOR STRUT CLAMPS/PIPE STRAPS

(SOURCE: MFMA, METAL FRAMING MANUFACTURERS ASSOCIATION; STANDARDS PUBLICATION, PP 21-26)

9.1.3 PULLOUT TEST – CLAMP (STRAP) FROM CHANNEL

The clamp shall be installed into the slot opening of the channel and around a section of conduit, pipe, or tubing of the proper size. The conduit, pipe, or tubing shall be of a length at least equal to the width of the channel.

The threaded fastener shall be inserted and tightened to a torque as given in 9.1.1. The back of the channel shall be rigidly secured and the test pullout load shall be applied equally to points on the conduit pipe or tubing equidistant from the center of the clamp in a direction perpendicular to the plane of the slot side of the channel as shown in Figures 8 or 9.

Pullout failure shall be the point of maximum load where yielding continues without any increase in the load.

The rate of loading shall not exceed 1/2 inch per minute.

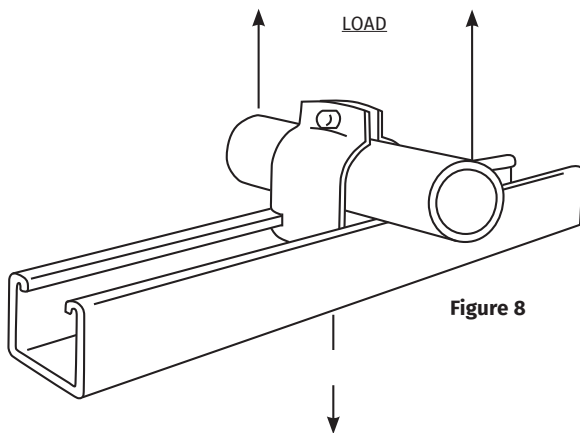

Figure 8

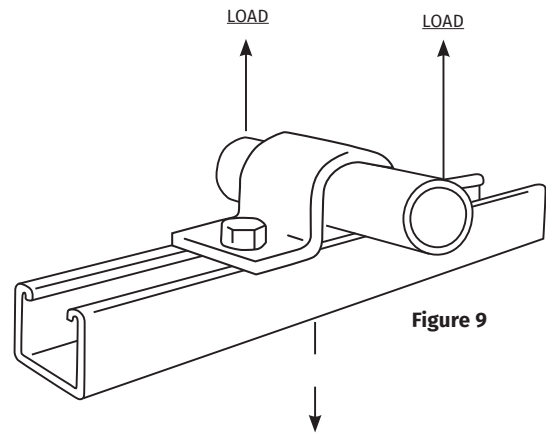

Figure 9

NOTE: This test shall be evaluated in accordance with the applicable section of the AISI "Specification for the Design of Cold-Formed Steel Structural Members," latest edition.

TESTING PARAMETERS FOR STRUT CLAMPS/PIPE STRAPS

9.1.4 SLIP TEST – CLAMP (STRAP) ALONG CHANNEL

The clamp shall be installed into the slot opening of the channel and around a section of conduit, pipe, or tubing of the proper size. The conduit, pipe, or tubing shall be of a length at least equal to the width of the channel.

The threaded fastener shall be inserted and tightened to a torque as given in 9.1.1.

The back of the channel shall be rigidly secured and the test slip load shall be applied equally to points on the conduit, pipe, or tubing equidistant from the center of the clamp in a direction parallel to the plane of the slot side of the channel as shown in Figures 10 or 11.

Failure shall be the point of maximum load where yielding or slipping continues without any increase in the load.

The rate of loading shall not exceed 1/2 inch per minute.

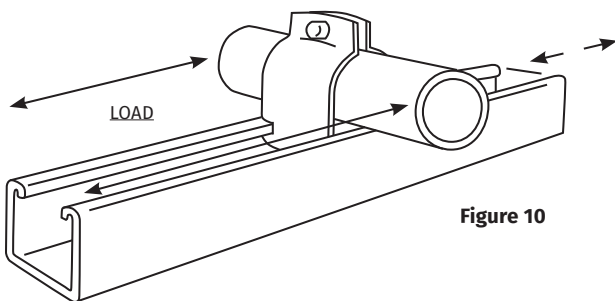

Figure 10

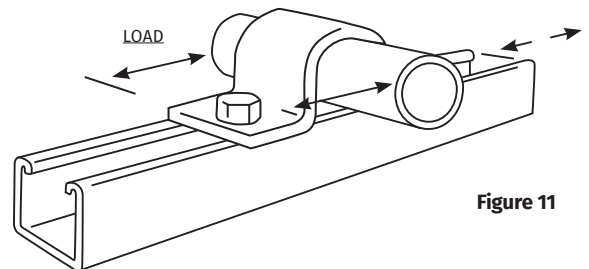

Figure 11

NOTE: This test shall be evaluated in accordance with the applicable section of the AISI "Specification for the Design of Cold-Formed Steel Structural Members," latest edition.

TESTING PARAMETERS FOR STRUT CLAMPS/PIPE STRAPS

9.1.5 SLIP TEST – CONDUIT, PIPE, OR TUBING THROUGH CLAMP (STRAP)

The clamp shall be installed into the slot opening of the channel and around a section of conduit, pipe, or tubing of the proper size. The conduit, pipe, or tubing shall be of a length at least equal to the width of the channel.

The threaded fastener shall be inserted and tightened to a torque as given in 9.1.1.

The channel shall be rigidly secured and the test load shall be applied axially to the conduit, pipe, or tubing as shown in Figures 12 or 13.

Failure shall be the point of maximum load where yielding or slipping continues without any increase in the load.

The rate of loading shall not exceed 1/2 inch per minute.

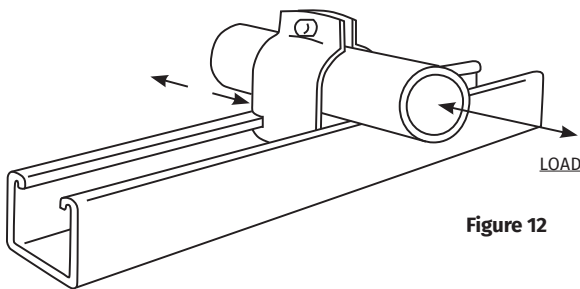

Figure 12

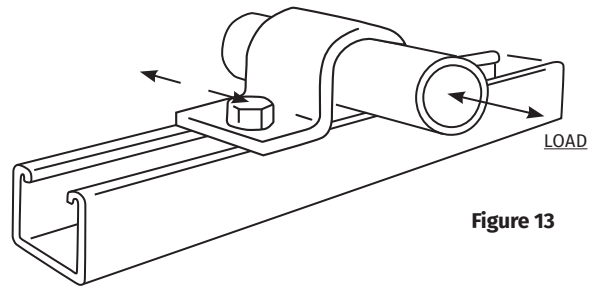
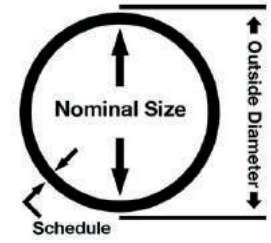

Figure 13

NOTE: This test shall be evaluated in accordance with the applicable section of the AISI "Specification for the Design of Cold-Formed Steel Structural Members," latest edition.



OUTSIDE DIAMETER PIPE QUICK REFERENCE SHEET

PIPE SIZE	COPPER TUBE OO	STEEL PIPE OO	CAST IRON PIPE OO	CAST IRON HEAVY WT. OO	PVC SCH 40 OO	EMT THIN WALL CONDUIT OO
IN.	IN.	IN.	IN.	IN.	IN.	IN.
1/8"	0.405	0.405	N/A	N/A	N/A	N/A
1/4"	.54	.54	N/A	N/A	N/A	N/A
3/8"	0.675	0.675	N/A	N/A	N/A	N/A
1/2"	0.84	.84	N/A	N/A	0.84	0.706
3/4"	1.05	1.05	N/A	N/A	1.05	0.922
1"	1.315	1.315	N/A	N/A	1.315	1.163
1 1/4"	1.66	1.66	N/A	N/A	1.66	1.51
1 1/2"	1.9	1.9	N/A	N/A	1.9	1.74
2"	2.375	2.375	2.3	2.38	2.375	2.197
2 1/2"	2.875	2.875	N/A	N/A	2.875	2.875
3"	3.5	3.5	3.3	3.5	3.5	3.5
3 1/2"	4	4	0	N/A	N/A	4
4"	4.5	4.5	4.3	4.5	4.5	4.5
5"	5.563	5.563	5.3	5.5	5.563	N/A
6"	6.625	6.625	6.3	6.5	6.625	N/A
8"	8.625	8.625	8.38	8.62	8.625	N/A
10"	10.75	10.75	10.5	10.75	10.75	N/A
12"	N/A	12.75	12.5	12.75	12.75	N/A

*NOTE: *These are approximate pipe sizes by type. Always check with the pipe manufacturer for exact dimension.*



Visit gregorystrut.com or call 866-99STRUT to learn more.