

Gauge and Depth

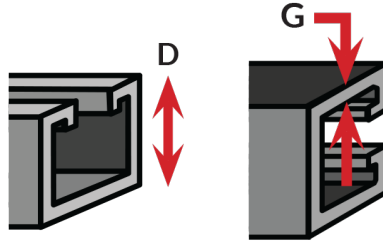

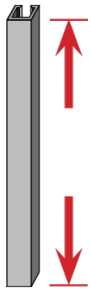

12 GAUGE 0.102
1-5/8" x 13/16" D

Length



- STANDARD 10' (Shorter runs for easy handling)
- STANDARD 20' (Typical for longer runs)
- 6'8" (Typical for commercial joists distance)
- CUSTOM CUT-TO-LENGTH

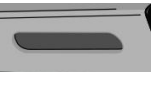

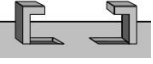

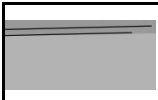
Perforation

	OVAL SLOT (Half slot) [9/16" x 11/8" x 2" on ctr.]
	LONG SLOT (Elongated slot) [13/32" x 3" x 4" on ctr.]
	ROUND HOLE [9/16" DIAM x 1-7/8" on ctr.]
	KNOCK OUT [7/8" DIAM x 6" on ctr.]
	CONTINUOUS CONCRETE INSERT



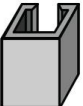



SOLID (No perforation)

Material

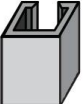

	<p>STEEL (Carbon steel, structural grade, 33,000 min yield)</p>
	<p>STAINLESS STEEL [304 or 316]</p>
	<p>ALUMINUM</p>
	<p>FIBERGLASS</p>

Finish

	<p>PRE-GALVANIZED (Continuous galvanized) - G90 zinc coating weight for cost-effective long-term galvanic and barrier corrosion protection</p>
	<p>HOT DIPPED Galvanized (HDG - after fabrication, batch dip) where aqueous or exterior applications require greater corrosion protection</p>
	<p>GREEN Powder or "e"-coated painted topical coating</p>
	<p>PVC COAT Heavy PVC coat for extended barrier protection or cosmetic effects (May PVC coat over plain or galvanized)</p>
	<p>WIZCoat™ GALVANNEAL Paintable pregalvanized material requires no pre-treatment. Easily spray painted post-installation</p>



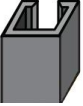

G132 SERIES METAL FRAMING STRUT CHANNEL

	PLAIN Untreated, "plain" steel with no topical/barrier coating
	GOLD Yellow zinc dichromate electro-galvanized
	CUSTOM COLORS Custom powder coating available in virtually any color variations

Gregory G-STRUT Submittal Form

Project Name	
Project Start Date	
Architect or Engineer	
Phone	
Contractor(s)	
Address	
City	
State	
Zip	

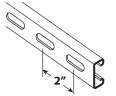
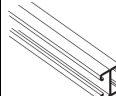
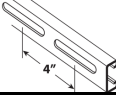
Approval

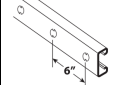
1-5/8" x 13/16" (1.625" x 0.8125") • 12 gauge (0.102" thick)			
	G132OS [Oval-Slot] 9/16" x 1-1/8" - 2" ON CTR		G132A [Back-to-Back] WELDED
	G132LS [Long-Slot] 13/32" x 3" - 4" ON CTR		G132AOS [Back-to-Back Oval-Slot] WELDED
	G132H [Holes] 9/16" DIAM. - 1-7/8" ON CTR		G132KO [KNOCK OUT] 7/8" DIAM. - 6" ON CTR

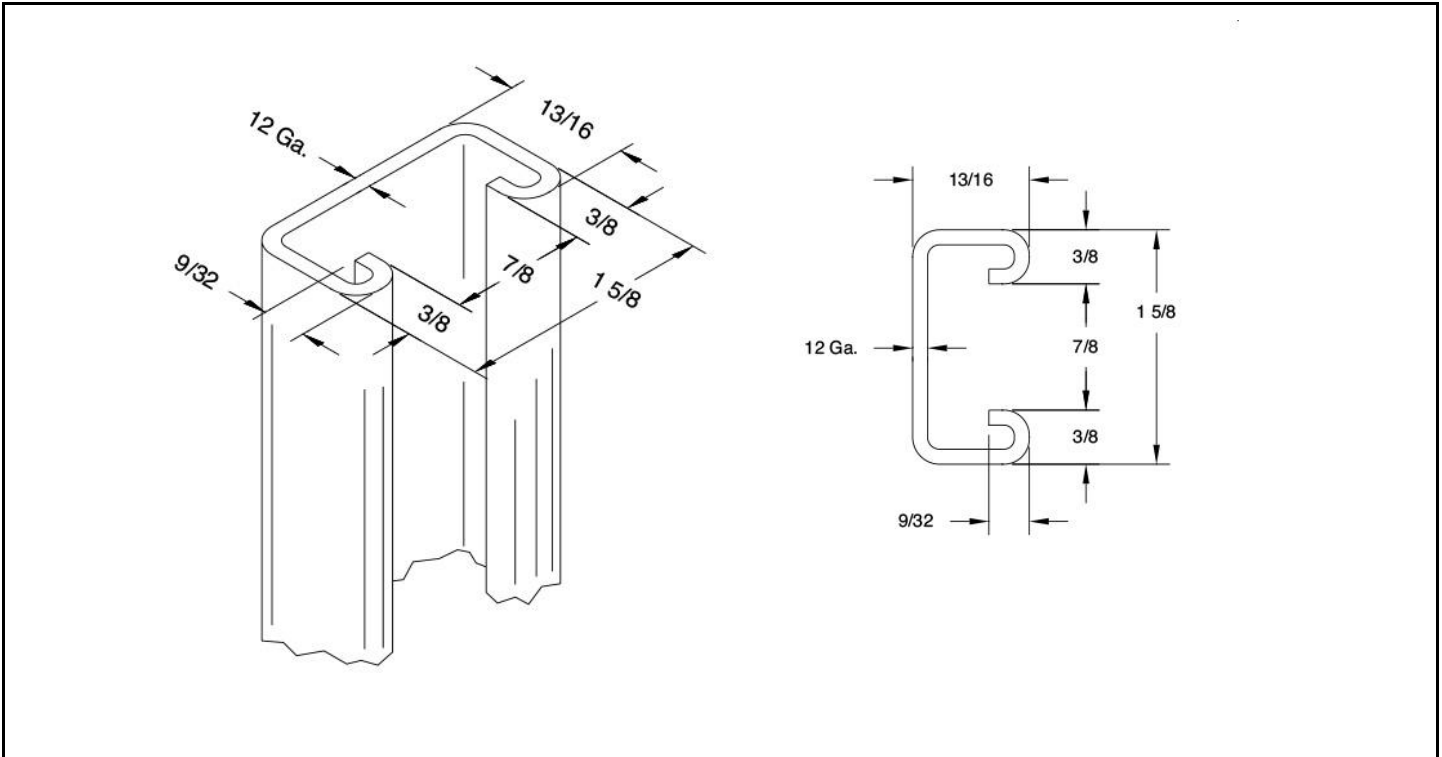

ITEM	QNT'Y	DESCRIPTION	MATERIAL
		ROLLFORM TOLERANCES	
SCALE	FULL	CHK'D BY	LENGTH ± 0.125"
DWN BY	IDI	02-02-02	APP'D BY
ALL OTHER DIMENSIONS ± 0.020"			

G-STRUT CHANNEL, PART # G132

CAD FILENAME G132	GREGORY STRUT PRODUCTS Division of GRegory Industries 4100 13th Street SW, Canton, OH 44710 PH: 330-477-4800 • FX: 330-477-0626	REF. No.
LAST PLOT DATE 02-02-02		DRWG No. G132

This drawing is the property of Gregory Strut Prod. and is loaned without other consideration than the agreement and condition that it is not to be reproduced, copied or otherwise disposed of, directly or indirectly, and is not to be used in whole or in part to assist in making or to furnish any information for the making of drawings, prints apparatus or parts thereof. This drawing shall be returned to Gregory Strut Prod. upon request. The acceptance of this drawing will be construed as an acceptance of the foregoing conditions, and as an admission of the exclusive ownership in and to the drawing of Gregory Strut products.

ELEMENTS OF SECTION								
			X-X AXIS			Y-Y AXIS		
Strut Section No.	Weight/ Foot lbs.	Area of Section in. ²	Moment of Inertia in. ⁴	Section Modulus in. ³	Radius of Gyration in.	Moment of Inertia in. ⁴	Section Modulus in. ³	Radius of Gyration in.
G132	1.262	0.371	0.029	0.06	0.28	0.134	0.165	0.601



G132 SERIES METAL FRAMING STRUT CHANNEL

G132A	2.525	0.742	0.137	0.169	0.43	0.268	0.33	0.601
-------	-------	-------	-------	-------	------	-------	------	-------

BEAM & COLUMN LOADS					
Strut Section Number	Beam Span or Column Height	Maximum Column Load	Total Uniform Load @25,000 psi	Deflection @ 25,000 psi	Uniform Load @ 1/240 Span Deflection
	in.	lbs.	lbs.	in.	lbs.
G132	12	6430	1000	0.02	-
	18	5860	660	0.05	-
	24	5180	500	0.1	-
	30	4410	400	0.16	290
	36	3530	330	0.23	200
	42	2630	280	0.32	150
	48	2020	250	0.42	110
	54	1590	220	0.53	90
	60	1290	200	0.66	70
	66	1060	180	0.8	60
	72	-	160	0.92	50
	84	-	140	1.28	30
	96	-	120	1.64	20
	108	-	110	2.14	20
	120	-	100	2.67	10
	132	-	90	3.2	10
	144	-	80	3.69	10
	156	-	70	4.11	10
	168	-	70	5.13	0
	180	-	60	5.41	0
	192	-	60	6.57	0
	204	-	50	6.57	0
	216	-	50	7.8	0
	228	-	50	9.17	0
	240	-	50	10.7	0

BEAM & COLUMN LOADS					
Strut Section Number	Beam Span or Column Height	Maximum Column Load	Total Uniform Load @25,000 psi	Deflection @ 25,000 psi	Uniform Load @ 1/240 Span Deflection



G132 SERIES METAL FRAMING STRUT CHANNEL

	in.	lbs.	lbs.	in.	lbs.
G132A	12	13720	2810	0.01	-
	18	13240	1870	0.03	-
	24	12690	1400	0.06	-
	30	12080	1120	0.09	-
	36	11400	930	0.14	-
	42	10670	800	0.19	720
	48	9880	700	0.25	550
	54	9030	620	0.31	430
	60	8120	560	0.39	350
	66	7150	510	0.48	290
	72	6110	460	0.56	240
	84	4490	400	0.77	180
	96	3440	350	1.01	130
	108	-	310	1.27	100
	120	-	280	1.58	80
	132	-	250	1.88	70
	144	-	230	2.25	60
	156	-	210	2.61	50
	168	-	200	3.1	40
	180	-	180	3.44	30
	192	-	170	3.94	30
	204	-	160	4.45	30
	216	-	150	4.95	20
	228	-	140	5.43	20
	240	-	140	6.34	20

For Perforated Channels, Reduce Total Beam Load Values as Follows:

G132/G132A	OS	22%
G132/G132A	LS	35%
G132/G132A	H	14%
G132/G132A	KO	6%

E = 29000; Fy = 42700; K = 0.8



G132 SERIES METAL FRAMING STRUT CHANNEL

COLUMN LOADS: Column loads are for allowable axial loads for the unsupported heights listed (including a K value of 0.80). Column loads must be reduced for eccentric loading.

BEAM LOADS: Loads listed are distributed uniformly. For loads concentrated at center of span, multiply uniform load by 0.5 and deflection by 0.8. Where deflection is not a factor, use stress of 25,000 PSI. When deflection is a factor, use deflection of 1/240 span.