

Gauge and Depth

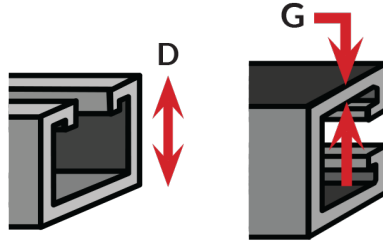

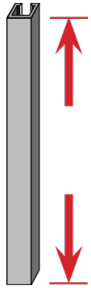

14 GAUGE 0.077
1-5/8" x 13/16" D

Length



- STANDARD 10' (Shorter runs for easy handling)
- STANDARD 20' (Typical for longer runs)
- 6'8" (Typical for commercial joists distance)
- CUSTOM CUT-TO-LENGTH

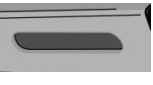

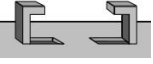

Perforation

	OVAL SLOT (Half slot) [9/16" x 11/8" x 2" on ctr.]
	LONG SLOT (Elongated slot) [13/32" x 3" x 4" on ctr.]
	ROUND HOLE [9/16" DIAM x 1-7/8" on ctr.]
	KNOCK OUT [7/8" DIAM x 6" on ctr.]
	CONTINUOUS CONCRETE INSERT



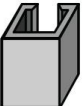



SOLID (No perforation)

Material

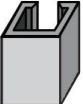

	<p>STEEL (Carbon steel, structural grade, 33,000 min yield)</p>
	<p>STAINLESS STEEL [304 or 316]</p>
	<p>ALUMINUM</p>
	<p>FIBERGLASS</p>

Finish

	<p>PRE-GALVANIZED (Continuous galvanized) - G90 zinc coating weight for cost-effective long-term galvanic and barrier corrosion protection</p>
	<p>HOT DIPPED Galvanized (HDG - after fabrication, batch dip) where aqueous or exterior applications require greater corrosion protection</p>
	<p>GREEN Powder or "e"-coated painted topical coating</p>
	<p>PVC COAT Heavy PVC coat for extended barrier protection or cosmetic effects (May PVC coat over plain or galvanized)</p>
	<p>WIZCoat™ GALVANNEAL Paintable pregalvanized material requires no pre-treatment. Easily spray painted post-installation</p>

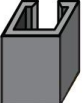

G134 SERIES METAL FRAMING STRUT CHANNEL

	PLAIN Untreated, "plain" steel with no topical/barrier coating
	GOLD Yellow zinc dichromate electro-galvanized
	CUSTOM COLORS Custom powder coating available in virtually any color variations

Gregory G-STRUT Submittal Form

Project Name	
Project Start Date	
Architect or Engineer	
Phone	
Contractor(s)	
Address	
City	
State	
Zip	

Approval

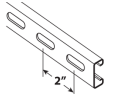
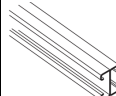
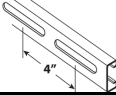
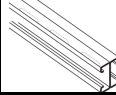
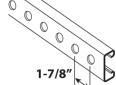
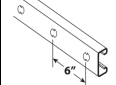
1-5/8" x 13/16" (1.625" x 0.8125") • 14 gauge (0.077" thick)			
	G134OS [Oval-Slot] 9/16" x 1-1/8" - 2" ON CTR		G134A [Back-to-Back] WELDED
	G134LS [Long-Slot] 13/32" x 3" - 4" ON CTR		G134AOS [Back-to-Back Oval-Slot] WELDED
	G134H [Holes] 9/16" DIAM. - 1-7/8" ON CTR		G134KO [KNOCK OUT] 7/8" DIAM. - 6" ON CTR

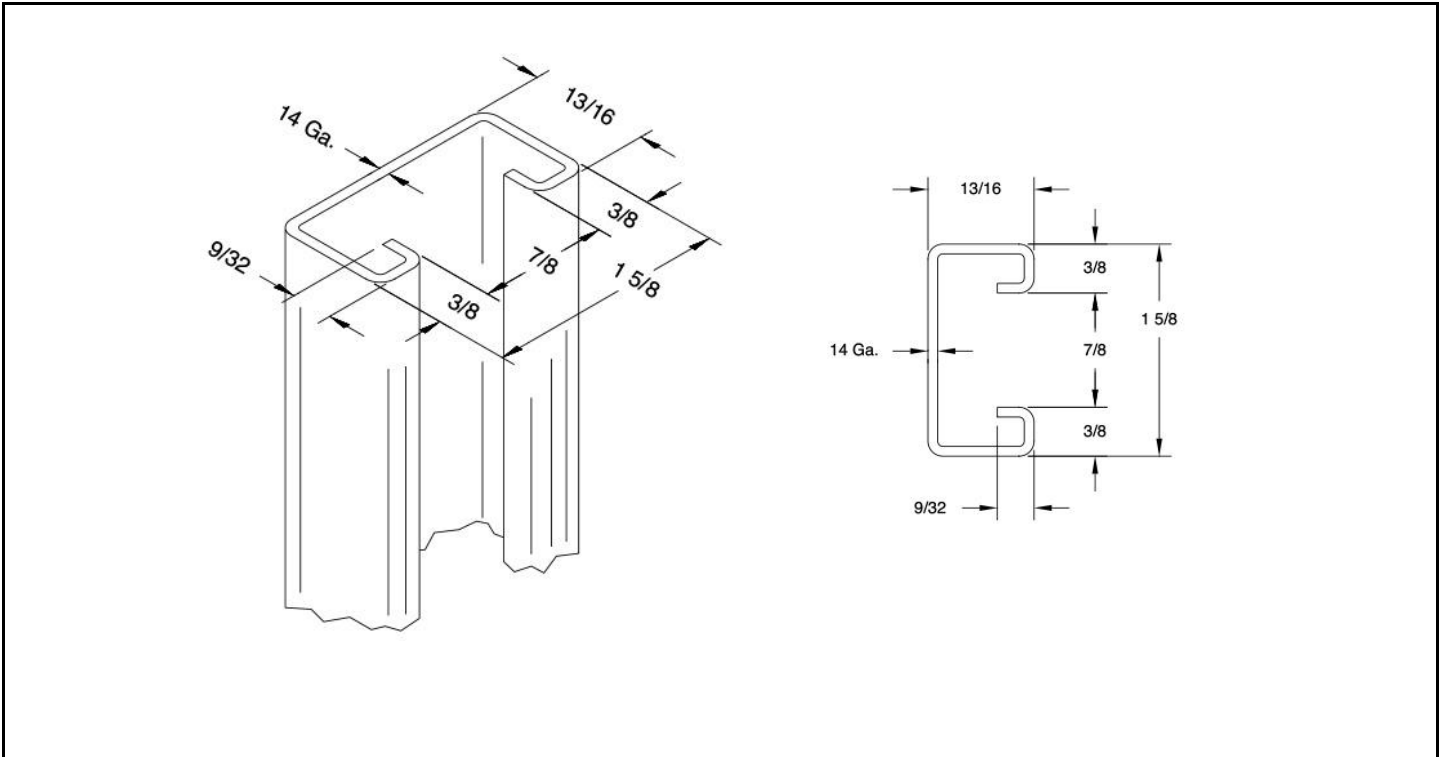

ITEM	QNT'Y	DESCRIPTION	MATERIAL
		ROLLFORM TOLERANCES	
SCALE	FULL	CHK'D BY	LENGTH ± 0.125"
DWN BY	IDI	02-02-02	APP'D BY
G-STRUT CHANNEL, PART # G134			
CAD FILENAME G134	GREGORY STRUT PRODUCTS Division of GRegory Industries		REF. No.
LAST PLOT DATE 02-02-02	4100 13th Street SW, Canton, OH 44710 PH: 330-477-4800 • FX: 330-477-0626		DRWG No. G134

This drawing is the property of Gregory Strut Prod. and is loaned without other consideration than the agreement and condition that it is not to be reproduced, copied or otherwise disposed of, directly or indirectly, and is not to be used in whole or in part to assist in making or to furnish any information for the making of drawings, prints apparatus or parts thereof. This drawing shall be returned to Gregory Strut Prod. upon request. The acceptance of this drawing will be construed as an acceptance of the foregoing conditions, and as an admission of the exclusive ownership in and to the drawing of Gregory Strut products.

ELEMENTS OF SECTION								
			X-X AXIS			Y-Y AXIS		
Strut Section No.	Weight/ Foot lbs.	Area of Section in. ²	Moment of Inertia in. ⁴	Section Modulus in. ³	Radius of Gyration in.	Moment of Inertia in. ⁴	Section Modulus in. ³	Radius of Gyration in.
G134	1.000	0.294	0.025	0.052	0.292	0.109	0.134	0.609



G134 SERIES METAL FRAMING STRUT CHANNEL

G134A	2.001	0.588	0.115	0.142	0.442	0.218	0.268	0.609
-------	-------	-------	-------	-------	-------	-------	-------	-------

BEAM & COLUMN LOADS					
Strut Section Number	Beam Span or Column Height	Maximum Column Load	Total Uniform Load @25,000 psi	Deflection @ 25,000 psi	Uniform Load @ 1/240 Span Deflection
	in.	lbs.	lbs.	in.	lbs.
G134	12	5220	860	0.02	-
	18	4800	570	0.05	-
	24	4300	430	0.1	-
	30	3730	340	0.16	250
	36	3090	280	0.23	170
	42	2380	240	0.31	130
	48	1820	210	0.41	100
	54	1440	190	0.53	70
	60	1170	170	0.65	60
	66	960	150	0.77	50
	72	-	140	0.93	40
	84	-	120	1.27	30
	96	-	100	1.58	20
	108	-	90	2.03	10
	120	-	80	2.48	10
	132	-	70	2.89	10
	144	-	70	3.75	10
	156	-	60	4.09	0
	168	-	60	5.1	0
	180	-	50	5.23	0
	192	-	50	6.35	0
	204	-	50	7.62	0
	216	-	40	7.23	0
	228	-	40	8.51	0
	240	-	40	9.93	0

BEAM & COLUMN LOADS					
Strut Section Number	Beam Span or Column Height	Maximum Column Load	Total Uniform Load @25,000 psi	Deflection @ 25,000 psi	Uniform Load @ 1/240 Span Deflection



G134 SERIES METAL FRAMING STRUT CHANNEL

	in.	lbs.	lbs.	in.	lbs.
G134A	12	11060	2360	0.01	-
	18	10690	1570	0.03	-
	24	10270	1180	0.06	-
	30	9790	940	0.09	-
	36	9270	780	0.14	-
	42	8700	670	0.19	600
	48	8090	590	0.25	460
	54	7440	520	0.31	360
	60	6740	470	0.39	290
	66	6000	430	0.48	240
	72	5170	390	0.56	200
	84	3790	330	0.76	150
	96	2900	290	1	110
	108	2290	260	1.27	90
	120	-	230	1.55	70
	132	-	210	1.88	60
	144	-	190	2.21	50
	156	-	180	2.66	40
	168	-	160	2.96	30
	180	-	150	3.41	30
	192	-	140	3.86	20
	204	-	130	4.3	20
	216	-	130	5.11	20
	228	-	120	5.55	20
	240	-	110	5.93	10

For Perforated Channels, Reduce Total Beam Load Values as Follows:

G134/G134A	OS	22%
G134/G134A	LS	35%
G134/G134A	H	14%
G134/G134A	KO	6%

E = 29000; Fy = 42700; K = 0.8



G134 SERIES METAL FRAMING STRUT CHANNEL

COLUMN LOADS: Column loads are for allowable axial loads for the unsupported heights listed (including a K value of 0.80). Column loads must be reduced for eccentric loading.

BEAM LOADS: Loads listed are distributed uniformly. For loads concentrated at center of span, multiply uniform load by 0.5 and deflection by 0.8. Where deflection is not a factor, use stress of 25,000 PSI. When deflection is a factor, use deflection of 1/240 span.