

Gauge and Depth

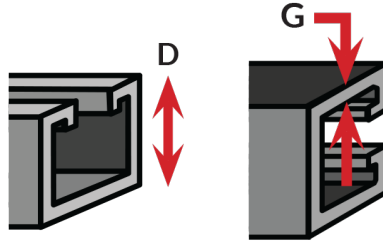

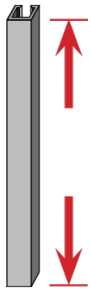

12 GAUGE 0.102
1-5/8" x 3-1/4" D

Length





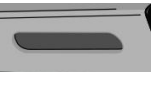

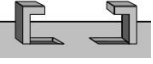
- STANDARD 10' (Shorter runs for easy handling)
- STANDARD 20' (Typical for longer runs)
- 6'8" (Typical for commercial joists distance)
- CUSTOM CUT-TO-LENGTH

Perforation



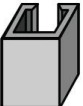

| | |
|------------------------------------------------------------------------------------|--------------------------------------------------------------|
|  | OVAL SLOT (Half slot) [9/16" x 11/8" x 2" on ctr.] |
|  | LONG SLOT (Elongated slot) [13/32" x 3" x 4" on ctr.] |
|  | ROUND HOLE [9/16" DIAM x 1-7/8" on ctr.] |
|  | KNOCK OUT [7/8" DIAM x 6" on ctr.] |
|  | CONTINUOUS CONCRETE INSERT |

| | |
|----------------------------------------------------------------------------------|-------------------------------|
|  | SOLID (No perforation) |
|----------------------------------------------------------------------------------|-------------------------------|

| Material | |
|-----------------|--|
|-----------------|--|

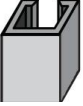

| | |
|------------------------------------------------------------------------------------|-----------------------------------------------------------------|
|  | STEEL (Carbon steel, structural grade, 33,000 min yield) |
|  | STAINLESS STEEL [304 or 316] |
|  | ALUMINUM |
|  | FIBERGLASS |

| Finish | |
|---------------|--|
|---------------|--|

| | |
|-------------------------------------------------------------------------------------|------------------------------------------------------------------------------------------------------------------------------------------------|
|  | PRE-GALVANIZED (Continuous galvanized) - G90 zinc coating weight for cost-effective long-term galvanic and barrier corrosion protection |
|  | HOT DIPPED Galvanized (HDG - after fabrication, batch dip) where aqueous or exterior applications require greater corrosion protection |
|  | GREEN Powder or "e"-coated painted topical coating |
|  | PVC COAT Heavy PVC coat for extended barrier protection or cosmetic effects (May PVC coat over plain or galvanized) |
|  | WIZCoat™ GALVANNEAL Paintable pregalvanized material requires no pre-treatment. Easily spray painted post-installation |

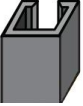

G812 SERIES METAL FRAMING STRUT CHANNEL

| | |
|-----------------------------------------------------------------------------------|----------------------------------------------------------------------------------------|
|  | PLAIN Untreated, "plain" steel with no topical/barrier coating |
|  | GOLD Yellow zinc dichromate electro-galvanized |
|  | CUSTOM COLORS Custom powder coating available in virtually any color variations |

Gregory G-STRUT Submittal Form

| | |
|-----------------------|--|
| Project Name | |
| Project Start Date | |
| Architect or Engineer | |
| Phone | |
| Contractor(s) | |
| Address | |
| City | |
| State | |
| Zip | |

Approval

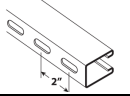
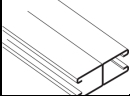
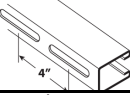
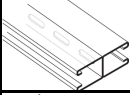
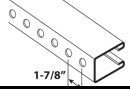
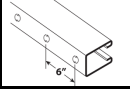
| 1-5/8" x 3-1/4" (1.625" x 3.25") • 12 gauge (0.102" thick) | | | |
|-------------------------------------------------------------------------------------|---------------------------------------------------------|-------------------------------------------------------------------------------------|-----------------------------------------------------|
|  | G812OS [Oval-Slot] 9/16" x 1-1/8" - 2" ON CTR |  | G812A [Back-to-Back] WELDED |
|  | G812LS [Long-Slot] 13/32" x 3" - 4" ON CTR |  | G812AOS [Back-to-Back Oval-Slot] WELDED |
|  | G812H [Holes] 9/16" DIAM. - 1-7/8" ON CTR |  | G812KO [KNOCK OUT] 7/8" DIAM. - 6" ON CTR |

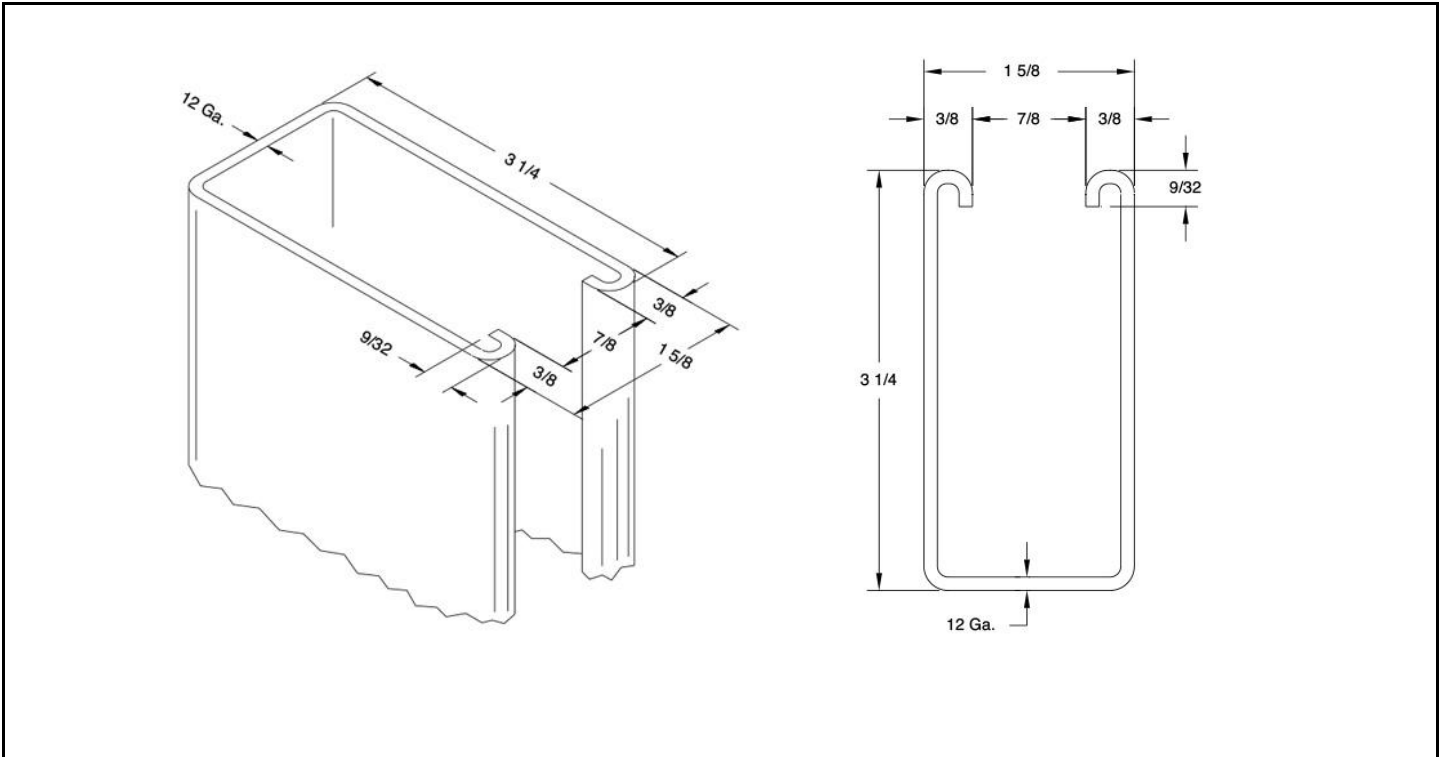

| ITEM | QNT'Y | DESCRIPTION | MATERIAL |
|-------------------------------------|------------------------------------------------------------------------------|---------------------|-------------------------|
| | | ROLLFORM TOLERANCES | |
| SCALE | FULL | CHK'D BY | LENGTH ± 0.125" |
| DWN BY | IDI | 02-02-02 | APP'D BY |
| G-STRUT CHANNEL, PART # G812 | | | |
| CAD FILENAME G812 | GREGORY STRUT PRODUCTS Division of GRegory Industries | | REF. No. |
| LAST PLOT DATE 02-02-02 | 4100 13th Street SW, Canton, OH 44710 PH: 330-477-4800 • FX: 330-477-0626 | | DRWG No. G812 |

This drawing is the property of Gregory Strut Prod. and is loaned without other consideration than the agreement and condition that it is not to be reproduced, copied or otherwise disposed of, directly or indirectly, and is not to be used in whole or in part to assist in making or to furnish any information for the making of drawings, prints apparatus or parts thereof. This drawing shall be returned to Gregory Strut Prod. upon request. The acceptance of this drawing will be construed as an acceptance of the foregoing conditions, and as an admission of the exclusive ownership in and to the drawing of Gregory Strut products.

| ELEMENTS OF SECTION | | | | | | | | |
|---------------------|-------------------|----------------------------------|------------------------------------|----------------------------------|------------------------|------------------------------------|----------------------------------|------------------------|
| | | | X-X AXIS | | | Y-Y AXIS | | |
| Strut Section No. | Weight/ Foot lbs. | Area of Section in. ² | Moment of Inertia in. ⁴ | Section Modulus in. ³ | Radius of Gyration in. | Moment of Inertia in. ⁴ | Section Modulus in. ³ | Radius of Gyration in. |
| | | | | | | | | |



G812 SERIES METAL FRAMING STRUT CHANNEL

| | | | | | | | | |
|-------|-------|-------|-------|-------|-------|-------|-------|-------|
| G812 | 2.957 | 0.869 | 1.061 | 0.605 | 1.105 | 0.422 | 0.519 | 0.697 |
| G812A | 5.914 | 1.738 | 6.006 | 1.848 | 1.859 | 0.844 | 1.039 | 0.697 |

| BEAM & COLUMN LOADS | | | | | |
|----------------------|----------------------------|---------------------|--------------------------------|-------------------------|--------------------------------------|
| Strut Section Number | Beam Span or Column Height | Maximum Column Load | Total Uniform Load @25,000 psi | Deflection @ 25,000 psi | Uniform Load @ 1/240 Span Deflection |
| | in. | lbs. | lbs. | in. | lbs. |
| G812 | 12 | 19540 | 10080 | 0 | - |
| | 18 | 19300 | 6720 | 0.01 | - |
| | 24 | 19030 | 5040 | 0.02 | - |
| | 30 | 18740 | 4030 | 0.04 | - |
| | 36 | 18420 | 3360 | 0.06 | - |
| | 42 | 18080 | 2880 | 0.09 | - |
| | 48 | 17730 | 2520 | 0.11 | - |
| | 54 | 17200 | 2240 | 0.14 | - |
| | 60 | 16390 | 2010 | 0.18 | - |
| | 66 | 15530 | 1830 | 0.22 | - |
| | 72 | 14640 | 1680 | 0.26 | - |
| | 84 | 12710 | 1440 | 0.36 | 1390 |
| | 96 | 10590 | 1260 | 0.47 | 1060 |
| | 108 | 8440 | 1120 | 0.59 | 840 |
| | 120 | 6840 | 1000 | 0.73 | 680 |
| | 132 | 5650 | 910 | 0.88 | 560 |
| | 144 | 4750 | 840 | 1.06 | 470 |
| | 156 | 4040 | 770 | 1.23 | 400 |
| | 168 | 3490 | 720 | 1.44 | 340 |
| | 180 | - | 670 | 1.65 | 300 |
| 192 | - | 630 | 1.88 | 260 | |
| 204 | - | 590 | 2.11 | 230 | |
| 216 | - | 560 | 2.38 | 210 | |
| 228 | - | 530 | 2.65 | 180 | |
| 240 | - | 500 | 2.92 | 170 | |

| |
|---------------------|
| BEAM & COLUMN LOADS |
|---------------------|



G812 SERIES METAL FRAMING STRUT CHANNEL

| Strut Section Number | Beam Span or Column Height | Maximum Column Load | Total Uniform Load @25,000 psi | Deflection @ 25,000 psi | Uniform Load @ 1/240 Span Deflection |
|----------------------|----------------------------|---------------------|--------------------------------|-------------------------|--------------------------------------|
| | in. | lbs. | lbs. | in. | lbs. |
| G812A | 12 | 39500 | 30800 | 0 | - |
| | 18 | 39270 | 20530 | 0 | - |
| | 24 | 39030 | 15400 | 0.01 | - |
| | 30 | 38770 | 12320 | 0.02 | - |
| | 36 | 38500 | 10260 | 0.03 | - |
| | 42 | 37360 | 8800 | 0.04 | - |
| | 48 | 35930 | 7700 | 0.06 | - |
| | 54 | 34400 | 6840 | 0.08 | - |
| | 60 | 32780 | 6160 | 0.09 | - |
| | 66 | 31070 | 5600 | 0.12 | - |
| | 72 | 29280 | 5130 | 0.14 | - |
| | 84 | 25420 | 4400 | 0.19 | - |
| | 96 | 21190 | 3850 | 0.25 | - |
| | 108 | 16890 | 3420 | 0.32 | - |
| | 120 | 13680 | 3080 | 0.39 | - |
| | 132 | 11300 | 2800 | 0.48 | - |
| | 144 | 9500 | 2560 | 0.57 | - |
| | 156 | 8090 | 2360 | 0.66 | 2290 |
| | 168 | 6980 | 2200 | 0.77 | 1970 |
| | 180 | - | 2050 | 0.89 | 1720 |
| | 192 | - | 1920 | 1.01 | 1510 |
| | 204 | - | 1810 | 1.14 | 1330 |
| | 216 | - | 1710 | 1.28 | 1190 |
| | 228 | - | 1620 | 1.43 | 1070 |
| | 240 | - | 1540 | 1.59 | 960 |

For Perforated Channels, Reduce Total Beam Load Values as Follows:

| | | |
|------------|----|-----|
| G812/G812A | OS | 20% |
| G812/G812A | LS | 33% |
| G812/G812A | H | 12% |



G812 SERIES METAL FRAMING STRUT CHANNEL

| | | |
|--------------------------------|----|----|
| G812/G812A | KO | 5% |
| E = 29000; Fy = 42700; K = 0.8 | | |

COLUMN LOADS: Column loads are for allowable axial loads for the unsupported heights listed (including a K value of 0.80). Column loads must be reduced for eccentric loading.

BEAM LOADS: Loads listed are distributed uniformly. For loads concentrated at center of span, multiply uniform load by 0.5 and deflection by 0.8. Where deflection is not a factor, use stress of 25,000 PSI. When deflection is a factor, use deflection of 1/240 span.