

SPOT CONCRETE INSERT

Finish: Electro-Galvanized

GSPCI
50/CTN
50 LBS/100

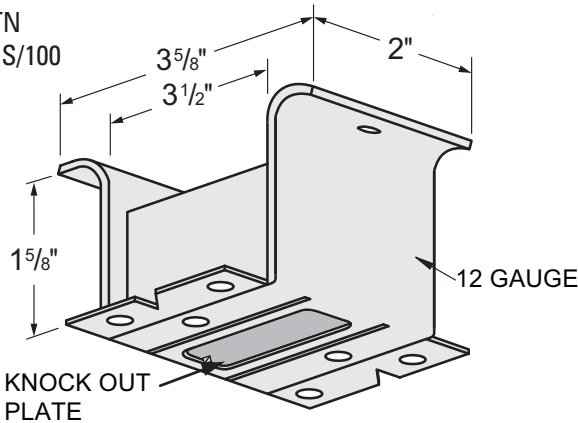

SQUARE SPOT INSERT NUT

Finish: Electro-Galvanized

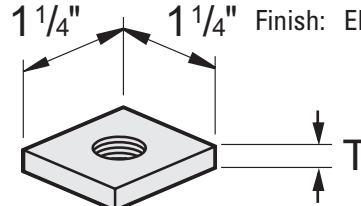

PART #	THREAD SIZE	THICK (T)	CARTON QTY.	LBS./ 100pcs
GSSI1/4	1/4-20	1/4"	100	10
GSSI3/8	3/8-16	3/8"	100	15
GSSI1/2	1/2-13	1/2"	100	18
GSSI5/8	5/8-11	1/2"	100	17
GSSI3/4	3/4-10	1/2"	100	15

CONTINUOUS CONCRETE INSERT

Finish: Pre-Galvanized

2 - SQUARE PUNCHES 13/16" WIDE x 1-7/8" LONG
REPEATS EVERY 4"
3/16" HOLE BETWEEN SQUARE PUNCHES
REPEATS EVERY 8"

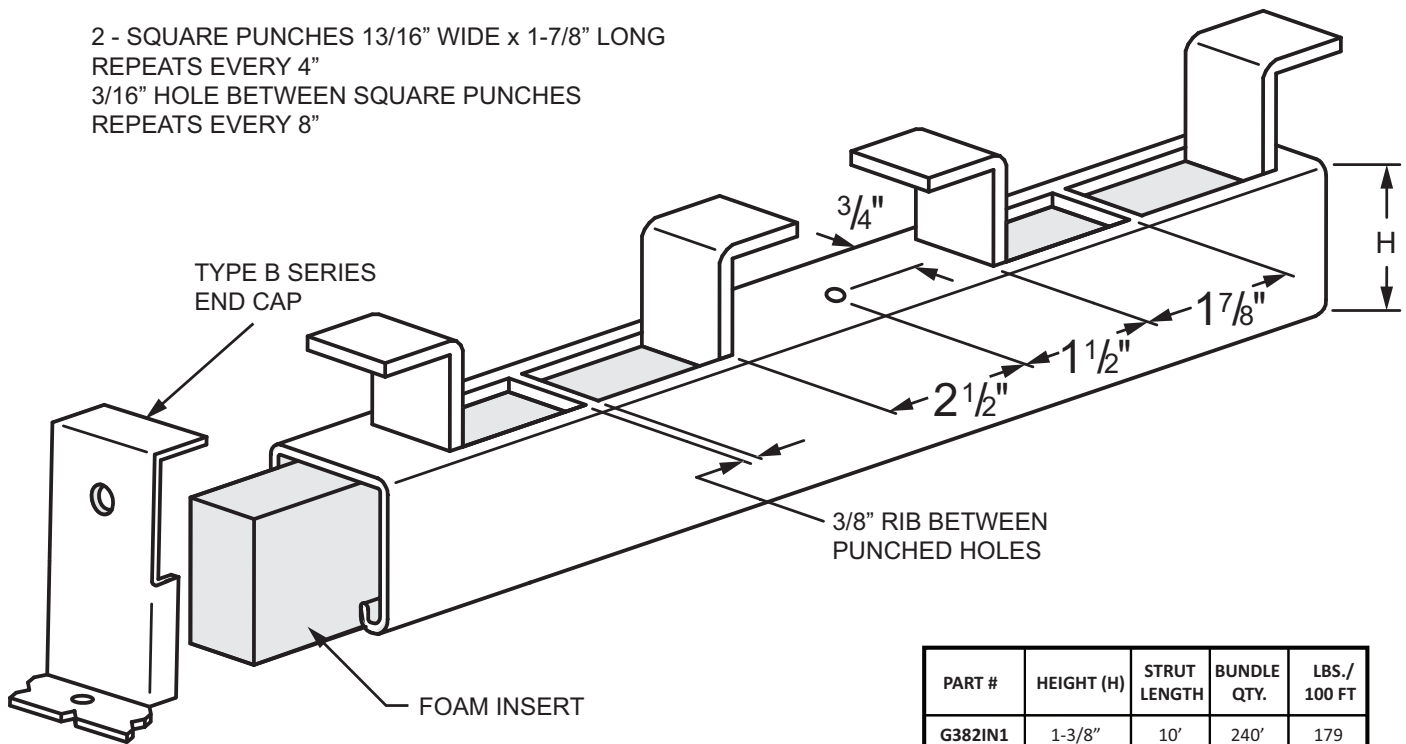

PART #	HEIGHT (H)	STRUT LENGTH	BUNDLE QTY.	LBS./ 100 FT
G382IN1	1-3/8"	10'	240'	179
G382IN2	1-3/8"	20'	480'	179
G132IN1	13/16"	10'	240'	135
G132IN2	13/16"	20'	480'	135
G582IN1	1-5/8"	10'	240'	199
G582IN2	1-5/8"	20'	480'	199

Continuous concrete inserts are the ideal alternative to drilling into concrete.

Available finishes include pre-galvanized, hot-dipped galvanized or plain. Standard lengths are 10' and 20'. Also available in multitude of custom lengths.