



U.S. Department
of Transportation

**Federal Highway
Administration**

December 27, 2006

400 Seventh St., S.W.
Washington, D.C. 20590

In Reply Refer To:
HSSD/B-88D

Mr. Michael Kempen
Safence, Incorporated
46-04 245th Street
Douglaston, NY 11362

Dear Mr. Kempen:

The Federal Highway Administration (FHWA) has previously accepted your tensioned 4-wire rope system, the Safence 350 4RI, as an National Cooperative Highway Research Program (NCHRP) Report 350 barrier at test level 3 (TL-3). In your October 11 letter and in an undated letter mailed to Mr. Richard Powers of my staff via Federal Express on December 18 you provided information on new tests run on two variations to the previously accepted design. Included with your requests were copies of the crash test reports prepared by the VTI test laboratory in Linkoping, Sweden under the direction of Mr. Jan Wenall and videos of the two tests. You requested formal acceptance of the modified design, called the Safence 3RC 350 TL4, at various post spacings and with corresponding design deflections.

The immediately obvious design change from your current system was the reduction in cables from four to three. Specifically, the second-from-the-bottom cable (originally set at 560 mm above the ground) was removed and the remaining three cables were left at their original heights of 480 mm, 640 mm, and 720 mm above the ground. The remaining changes were made to the line posts: the C-posts were fabricated from ATSM A50 steel in lieu of the A36 steel used in the earlier designs. Each post was also stiffened at the ground line by adding a steel plate inside the C-post to increase its resistance to bending, and a steel hook was added to the top of each post to retain the cables within the post center slot for a longer time upon barrier impact. These modifications are shown in the enclosure to this letter.

Two full-scale tests were conducted on the Safence 3RC 350 TL-4; one with an 8,000-kg single-unit truck and a post spacing of 4 meters, and a second with a 2000-kg pickup truck and a post spacing of 10 meters. The design deflection for the single-unit truck was reported as 2.1 meters with the 4-m post spacing. The design deflection for the pickup truck was reported as 3.7 meters with the 10-m post spacing. All the NCHRP Report 350 evaluation criteria were met in both tests. You also submitted mathematical calculations showing the estimated design deflection for post spacings from 1.5 to 10 meters based on the deflections actually seen in the tests described above. After reviewing this information, my staff agreed that these interpolated distances appear



reasonable based on a comparison with other high-tensioned 3-cable barriers that have been tested and may be used as general guidance. However, the FHWA policy has been to accept interpolated deflections officially only when the interpolation is bounded by two points established by crash tests with the same type vehicle. While the impact energies for test 4-11 and 4-12 are similar, the vehicle body types are so different that they can be expected to interact differently with the cables, thereby affecting the actual deflection distances. The FHWA has long ascertained that the design deflection distances reported for flexible and semi-rigid barriers, and especially cable barriers, are approximations based on the results of controlled tests and that actual deflections in the field will vary widely based on actual impact conditions. Thus, we consider differences in design deflections up to one or two feet to be relatively inconsequential for cable barriers and not representative of significant differences in barrier performance between otherwise similar designs.

Based on staff review of the information you provided, I agree that the Safence 3RC 350 TL-4 design, as described above and shown in the enclosure to this letter, can be classified as a TL-4 design and may be used on the National Highway System when selected by the appropriate transportation authority. Since this product is made from steel and is proprietary, the provisions of Sections 635.410 (Buy America) and 635.411 (Use of Proprietary Products) of Title 23 Code of Federal Regulations, copies of which have been previously sent to you, remain applicable to the Safence 3RC 350 TL-4 and earlier designs.

Sincerely yours,

/original signed by John R. Baxter/

John R. Baxter, P.E.
Director, Office of Safety Design
Office of Safety

Enclosure

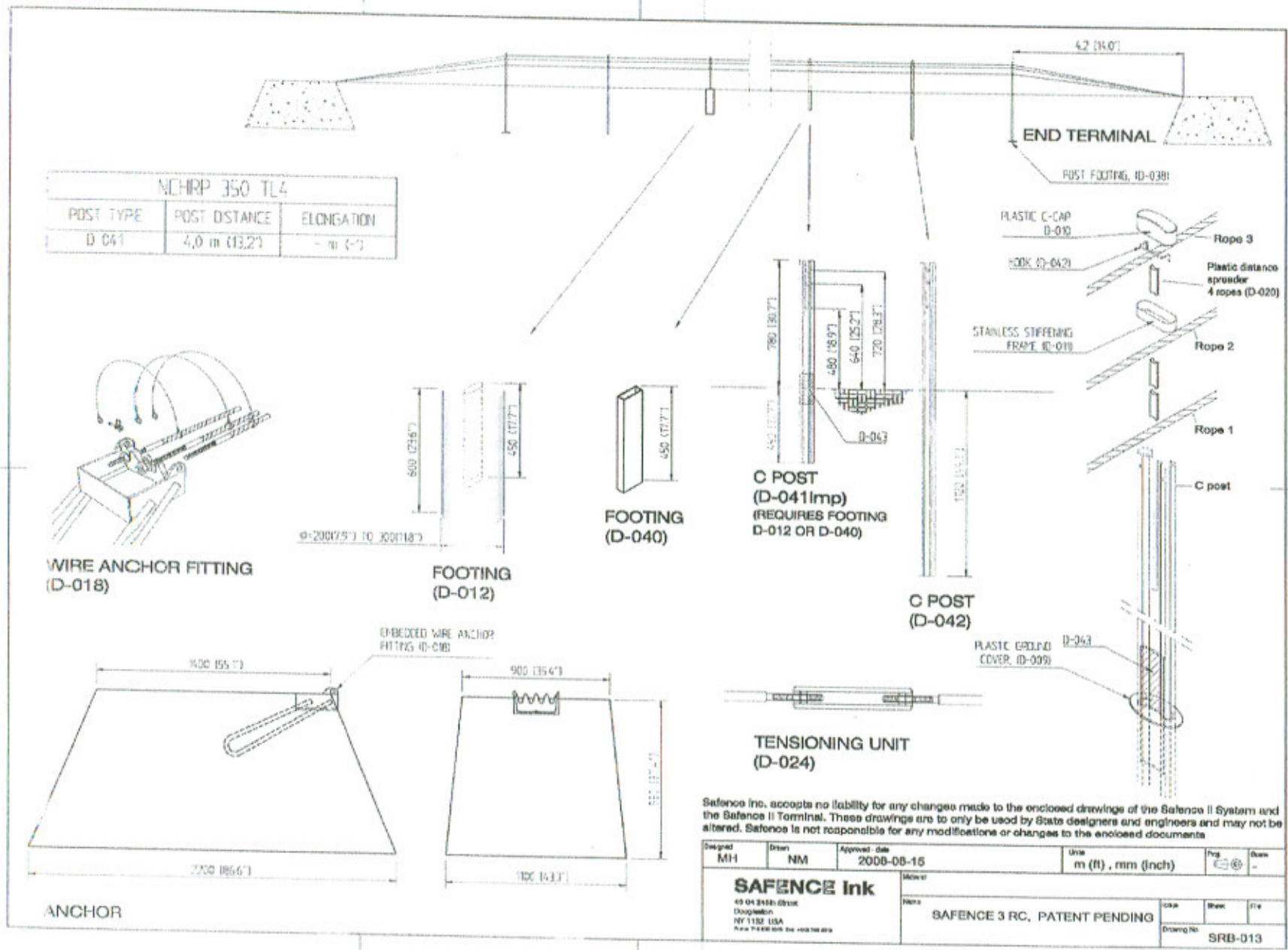

Safence Inc. accepts no liability for any changes made to the enclosed drawings of the Safence II System and the Safence II Terminal. These drawings are to only be used by State designers and engineers and may not be altered. Safence is not responsible for any modifications or changes to the enclosed documents.

Designed MH	Drawn NM	Approved date 2006-08-15	Units m (ft) , mm (inch)	Proj [Symbol]	Drawn -
SAFENCE Ink 49-04 24th Street Douglass NY 1122 USA New York 001 347 400 7000			SAFENCE 3 RC, PATENT PENDING		
Drawing No. SRB-013			Date Size Title		

Annex 10
Drawing of item

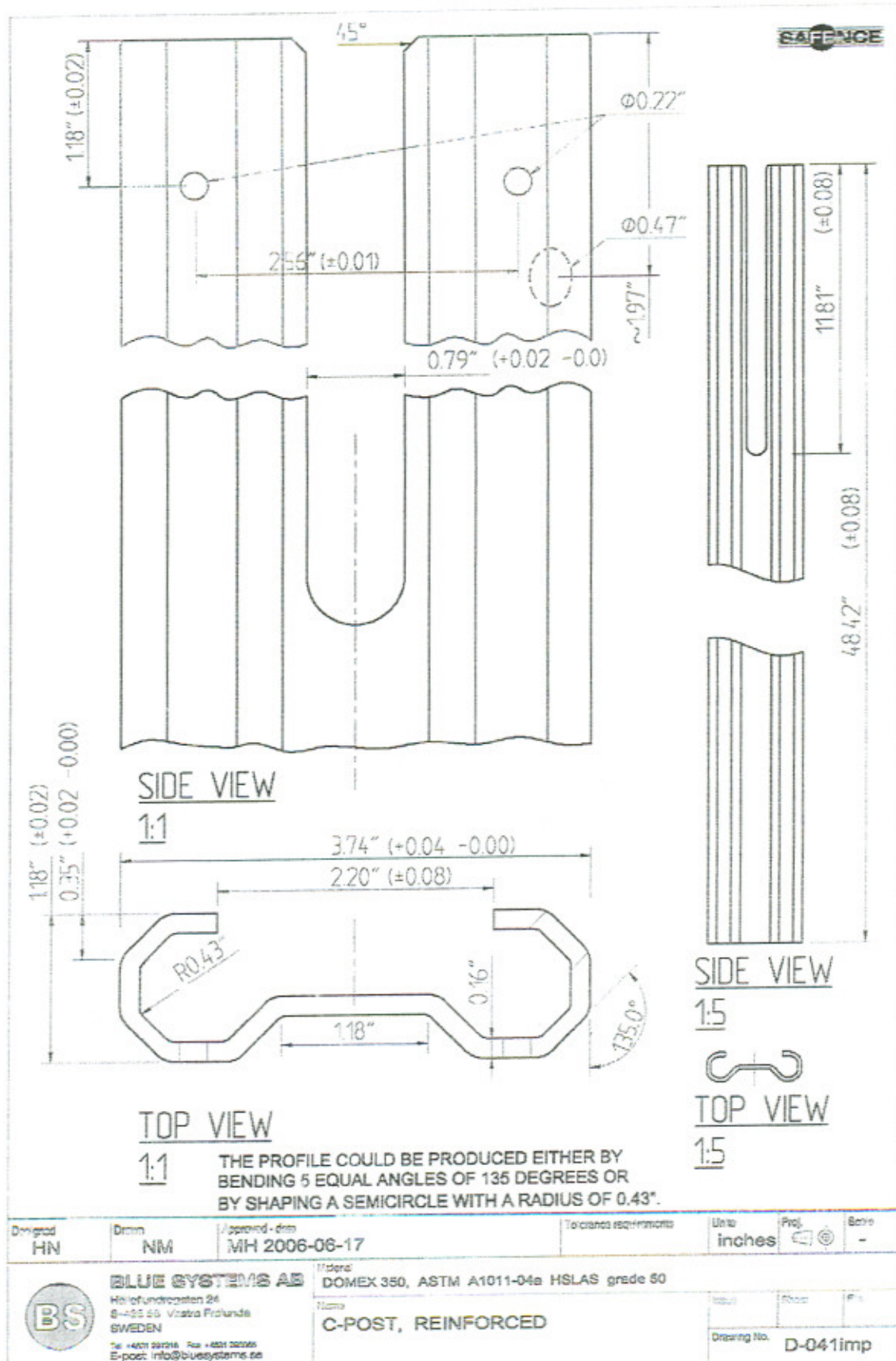

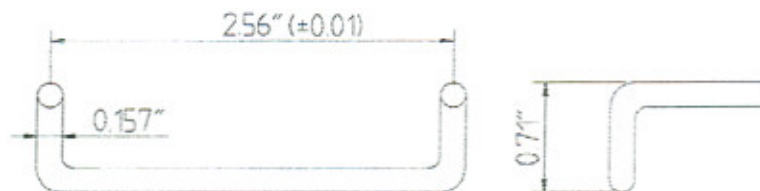

FRONT VIEW

SIDE VIEW



TOP VIEW

Designed HN	Drawn NM	Approved - date MH 2006-06-15	To customer requirements	Units inches	Proj. 	Scale 1:1
BLUE SYSTEMS AB Hälleforsvägen 24 S-416 48 Västra Frölunda SWEDEN Tel: +46 (0) 31 92 91 00 Fax: +46 (0) 31 92 91 01 E-post: info@bluesystems.se		Material AISI 304 Name C-POST HOOK, 4 mm		Drawing No. D-042imp		

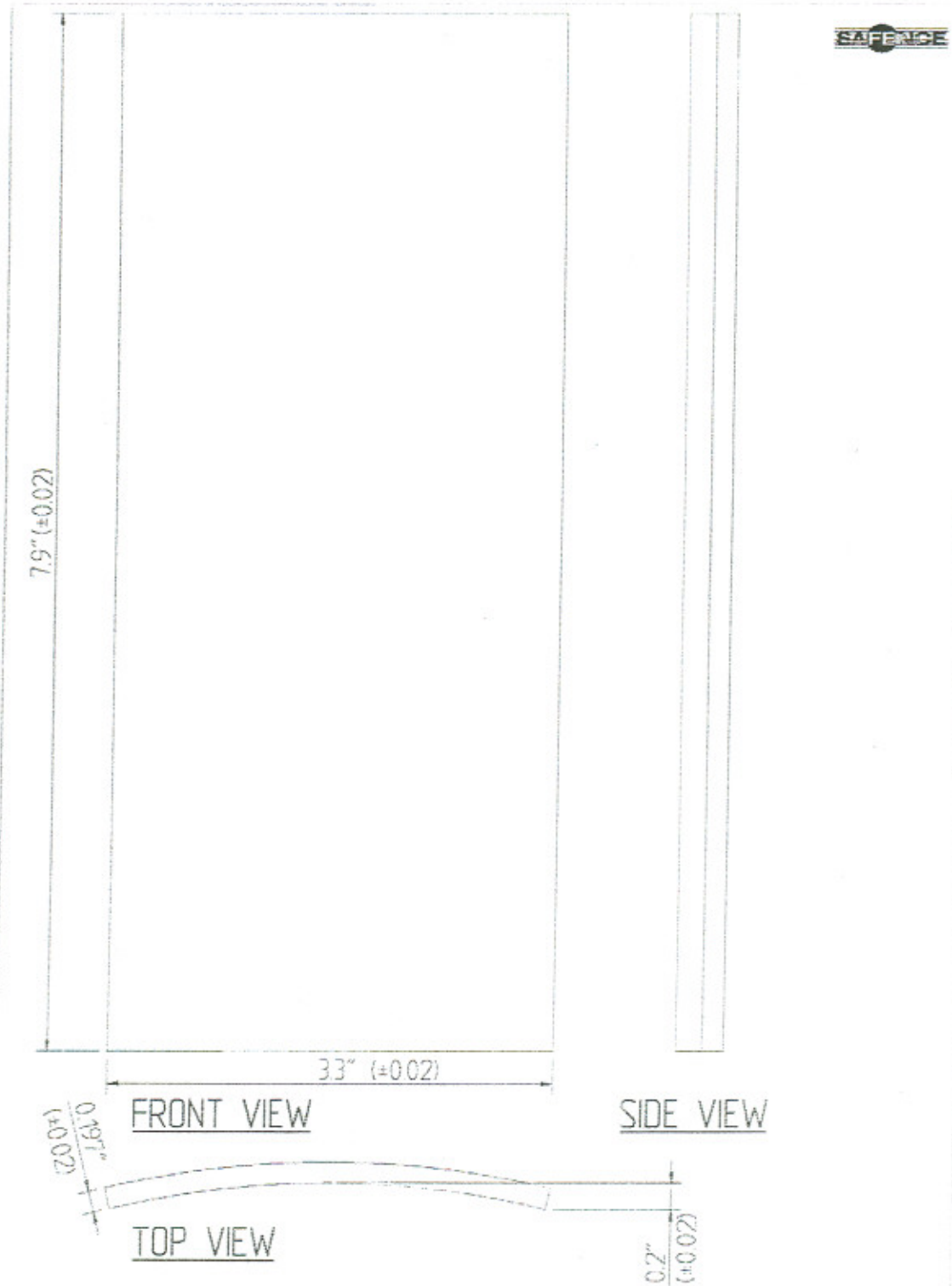

Designed HN	Drawn NM	Approved - date MH 2006-06-15	Tolerance requirements	Unit inches	Proj. 	Scale 1:1
 BLUE SYSTEMS AB Hårforsvägen 24 S-432 82 Västra Frånsta SWEDEN Tel: +46 8 29216 Fax: +46 8 29215 E-post: info@bluesystems.se			Material S235	Name STEEL PLATE FOR C-POST		
				Drawing No. D-043imp		