

Duplication for publication or sale is strictly prohibited
without prior written permission of the Transportation Research Board

Midwest Guardrail System for Standard and Special Applications

by

Ronald K. Faller, Ph.D., P.E.
Midwest Roadside Safety Facility
University of Nebraska-Lincoln
527 Nebraska Hall
Lincoln, Nebraska 68588-0529
Phone: (402) 472-6864
Fax: (402) 472-2022
Email: rfaller1@unl.edu

Karla A. Polivka, M.S.M.E., E.I.T.
Midwest Roadside Safety Facility
University of Nebraska-Lincoln
527 Nebraska Hall
Lincoln, Nebraska 68588-0529
Phone: (402) 472-9070
Fax: (402) 472-2022
Email: kpolivka2@unl.edu

Beau D. Kuipers, B.S.M.E., E.I.T.
Midwest Roadside Safety Facility
University of Nebraska-Lincoln
527 Nebraska Hall
Lincoln, Nebraska 68588-0529
Phone: (402) 472-9043
Fax: (402) 472-2022
Email: bkuiper1@bigred.unl.edu

Robert W. Bielenberg, M.S.M.E., E.I.T.
Midwest Roadside Safety Facility
University of Nebraska-Lincoln
527 Nebraska Hall
Lincoln, Nebraska 68588-0529
Phone: (402) 472-9064
Fax: (402) 472-2022
Email: rbielenberg2@unl.edu

John D. Reid, Ph.D.
Midwest Roadside Safety Facility
University of Nebraska-Lincoln
527 Nebraska Hall
Lincoln, Nebraska 68588-0529
Phone: (402) 472-3084
Fax: (402) 472-2022
Email: jreid1@unl.edu

John R. Rohde, Ph.D., P.E.
Midwest Roadside Safety Facility
University of Nebraska-Lincoln
527 Nebraska Hall
Lincoln, Nebraska 68588-0529
Phone: (402) 472-8807
Fax: (402) 472-2022
Email: jrohde@unl.edu

Dean L. Sicking, Ph.D., P.E.
Midwest Roadside Safety Facility
University of Nebraska-Lincoln
527 Nebraska Hall
Lincoln, Nebraska 68588-0529
Phone: (402) 472-9332
Fax: (402) 472-2022
Email: dsicking@unl.edu

submitted to

Transportation Research Board
83rd Annual Meeting
January 11-15, 2004
Washington, D.C.

November 15, 2003

Length of Paper: 7,586 (text) + 2500 (9 figures and 1 tables) = 10,086 words

ABSTRACT

Development, testing, and evaluation of the *Midwest Guardrail System* was continued from the original research started in 2000. This new strong-post W-beam guardrail system provides increased safety for impacts with higher center-of-mass vehicles. Additional design variations of the new *Midwest Guardrail System* included stiffened versions using reduced (half and quarter) post spacings as well as a standard guardrail design configured with a 152-mm (6-in.) high concrete curb. All full-scale vehicle crash tests were successfully performed in accordance with the Test Level 3 (TL-3) requirements specified in National Cooperative Highway Research Program (NCHRP) Report No. 350, Recommended Procedures for the Safety Performance Evaluation of Highway Features.

The research study also included dynamic bogie testing on steel posts placed at various embedment depths and computer simulation modeling with BARRIER VII to analyze and predict dynamic guardrail performance. Recommendations for the placement of the original *Midwest Guardrail System* as well as its stiffened variations were also made.

Keywords: Crash Testing, Longitudinal Barrier, Guardrail, Guardrail Placement, Computer Simulation, BARRIER VII, and Curbs

INTRODUCTION

For more than 50 years, strong-post W-beam guardrail systems have been placed along our highways and roadways in order to prevent errant motorists from striking dangerous hazards located beyond the roadway edge. In general, these systems have consisted of a single, 2.66-mm (12-gauge) thick W-beam rail supported by steel or wood posts spaced 1,905-mm (75-in.) on center. Although several rail spacer (blockout) variations have existed throughout the United States, one common W-beam guardrail system incorporated a 203-mm (8-in.) deep wood blockout in conjunction with 530-mm (20 7/8-in.) and 686-mm (27-in.) center and top rail mounting heights, respectively. This guardrail design in particular is the most common barrier system in used today and has had a good safety performance for many years.

Although these original W-beam guardrail designs were successfully developed to contain and safely redirect full-size sedans and later small cars, one research study indicated a performance weakness for standard guardrail designs. In 1983, the Texas Transportation Institute (TTI) conducted a large research study to determine the performance limits of the G4(1S), modified G4(2W), and modified G4(1S) longitudinal barrier systems (1). For this effort, seven crash tests were performed into strong-post W-beam guardrail systems using several vehicle types, including a sedan, small cars, pickup trucks, and a van. Several important conclusions could be made from these tests. First, a standard wood-post W-beam guardrail system installed to a 762-mm (30-in.) top mounting height could safely contain and redirect small cars with only limited wheel snag on the wood posts. The standard steel-post, steel blockout W-beam guardrail system was evaluated using small and 1/2-ton full-size pickup trucks and a van. Although this W-beam guardrail system was shown capable of safely containing and redirecting small and full-size pickup trucks, testing also revealed a tendency for the front wheel to severely snag on the posts. This wheel snag resulted in heavy damage to the front quarter and wheel assembly regions and a potential for a moderate vehicle roll angle while exiting the barrier. Finally, testing also showed that the steel-post W-beam guardrail system was incapable of safely redirecting a full-size van as the vehicle rolled over after exiting the barrier.

In 1993, the National Cooperative Highway Research Program (NCHRP) published Report No. 350, Recommended Procedures for the Safety Performance Evaluation of Highway Features (2) which provided new and revised crash testing guidelines as well as introduced the 3/4-ton pickup truck as a replacement to the full-size passenger sedan vehicle used previously. Following the implementation of these new impact safety standards, several crash testing studies were conducted in order to determine whether existing 686-mm (27-in.) high, strong steel- and wood-post W-beam guardrail systems would meet the new NCHRP Report No. 350 requirements (3-5). The results from these research studies revealed differing levels of safety performance. The wood-post, wood blockout guardrail system adequately contained and redirected the pickup truck, while the steel-post, with steel and wood blockout guardrail systems both resulted in vehicle rollover. During this same period, metrication of roadside safety hardware occurred and resulted in a repositioning of the W-beam rail center height to 550 mm (21.65 in.). As such, several research studies were performed in order to investigate the safety performance of 706-mm (27.78-in.) high strong-post, W-beam guardrail systems when subjected to 3/4-ton pickup truck impacts at the target conditions of 100 km/hr (62.14 mph) and 25 degrees (4,6-10). These studies included additional testing on steel-post, wood blockout W-beam

guardrail systems that resulted in either an acceptable or an unsatisfactory safety performance. Although most of these crash tests resulted in satisfactory barrier performance, there were indications that these W-beam guardrail systems may not have sufficient reserve capacity to safely contain and redirect higher center-of-mass vehicles during high-speed and high-angle collisions. Therefore, even though several strong-post W-beam guardrail designs meet the NCHRP Report No. 350 safety standards, there exists significant potential to improve the barrier's safety performance during impacts with high center-of-mass vehicles.

In 2000, the Midwest States' Regional Pooled Fund Program sponsored a research study at the Midwest Roadside Safety Facility (MwRSF) to develop a new guardrail system that would improve barrier performance for higher center-of-mass vehicles, provide reasonable barrier height tolerances, and reduce the potential for W-beam rupture (11-13). Relying heavily on LS-DYNA modeling (14), researchers investigated existing W-beam systems and made changes to those designs to improve barrier performance for higher center-of-mass vehicles while maintaining acceptable performance for small cars. These changes included: a new W-beam rail top mounting height of 787 mm (31 in.), a reduced guardrail post embedment depth, an increased blockout depth from 203 mm (8 in.) to 305 mm (12 in.), and a repositioning of the guardrail splice from a post to a midspan location. The early development efforts demonstrated that the new barrier system with an 813 mm (31 in.) mounting height could perform well during small car impacts. Although the barrier did pass a full-scale crash test with a ¾-ton pickup truck, the barrier's anchor was pulled completely out of the ground. Further, this research did not examine any alternative guardrail installation problems, such as placement adjacent to curb or reducing post spacing to limit lateral deflections. Hence, much additional research was necessary before the *Midwest Guardrail System* could be widely implemented.

As previously mentioned, longitudinal barrier systems are used for shielding roadside hazards. However, there often exist situations where limited space is available between the edge of the traveled way and the front of the hazard, such as when concrete bridge piers are found near the roadway shoulder. In these instances, it may be necessary for roadway designers to use stiffened variations of the standard W-beam guardrail system in order to reduce dynamic deflections and allow for a closer placement of the barrier to the hazard. In the past, computer simulation studies and full-scale crash testing programs have been utilized to better understand guardrail stiffening techniques, such as guardrail nesting and reduced post spacing, as well as to formulate guardrail placement guidelines (15-19). Therefore, before the *Midwest Guardrail System* can be widely implemented in the field, it will be necessary for researchers and roadway designers to better understand the dynamic performance of this new barrier system for both the stiffened and un-stiffened configurations. Once the dynamic performances of typical guardrail stiffening techniques for the *Midwest Guardrail System* are fully understood, minimum design recommendations for the placement of the various guardrail systems with respect to hazards can be determined.

Curbs are often utilized along the roadway edge to provide drainage control, roadway edge delineation and support, right-of-way reduction, sidewalk separation, as well as to perform several other functions. Since hazards are often found along roadways with curbs, W-beam guardrail systems are frequently installed over curbs. In recent years, two research studies were conducted to test and evaluate standard W-beam guardrail systems installed over 102-mm (4-in.) high curbs according to the NCHRP Report No. 350 guidelines (20-22). In 2000, TTI researchers

performed a study that showed that the G4(2W) guardrail system, when installed over a 102-mm (4-in.) high asphaltic curb, would adequately contain and redirect $\frac{3}{4}$ -ton pickup trucks. However, in a separate study, MwRSF engineers tested and evaluated the modified G4(1S) guardrail system when installed over a concrete curb and encountered unsatisfactory results. The W-beam guardrail ruptured at a splice location, allowing the vehicle to penetrate behind the system. Several alternatives were considered, including guardrail nesting, utilizing a single 3.42-mm (10-gauge) W-beam rail, and relocating the rail splice away from a post location. Researchers modified the guardrail system to use two nested 2.66-mm (12-gauge) W-beam rails. Pickup truck testing on this nested, modified G4(1S) guardrail system was met with satisfactory results. However, the vehicle was redirected into the air and landed on the barrier downstream. Both guardrail-to-curb combinations were constructed with the toe of the curb either at or within 25 mm (1 in.) of the rail face because past research has shown that curbs placed in front of W-beam guardrails can lead to the vehicle's climbing and vaulting over the barriers (21). Although these two W-beam guardrail systems installed over curbs adequately met the NCHRP Report No. 350 requirements, it is generally believed that W-beam guardrail systems with curbs higher than 102-mm (4-in.) tall, would not be capable of meeting current safety standards. Placement of the 102-mm (4-in.) high curbs farther away from the front face of the existing W-beam barriers system also may not be capable of meeting pickup truck crash testing requirements. Since the *Midwest Guardrail System* may be more accommodating to the higher center-of-mass vehicles, it may be feasible to utilize taller curbs in combination with the W-beam guardrail system as well as to consider their placement farther away from the front of the rail face. Placement of curbs at a greater distance in front of the guardrail face reduces the propensity for snow plows to gouge and/or damage the W-beam rail sections.

RESEARCH OBJECTIVE

The objectives of the research project were to: (1) continue the development of the *Midwest Guardrail System* in order to provide increased safety for higher center-of-mass vehicles, provide reasonable barrier height tolerances, and reduce the potential for W-beam rupture; (2) evaluate guardrail stiffening and determine appropriate guardrail placement guidelines for shielding rigid hazards using full-, half-, and quarter-post spacing designs; and (3) develop a guardrail-to-curb barrier combination that provides increased hydraulic capacity and placement farther in front of the rail face to reduce the frequency of snow plow damage to guardrails. All development and testing of the *Midwest Guardrail System* was conducted in accordance with Test Level 3 (TL-3) safety performance criteria set forth in NCHRP Report No. 350. This study was performed by MwRSF in cooperation with the Midwest States' Regional Pooled Fund Program.

TEST REQUIREMENTS AND EVALUATION CRITERIA

Longitudinal barriers, such as W-beam guardrail systems, must satisfy the requirements provided in NCHRP Report No. 350 to be accepted for use on new construction projects or whenever it becomes necessary to replace out-of-date designs. According to TL-3 of NCHRP Report No. 350, guardrail systems must be subjected to two full-scale vehicle crash tests: (1) a 2,000-kg (4,409-lb) pickup truck impacting at a speed of 100 km/hr (62.14 mph) and at an angle of 25

degrees; and (2) an 820-kg (1,808-lb) small car impacting at a speed of 100 km/hr (62.14 mph) and at an angle of 20 degrees. Finally, the full-scale vehicle crash tests were conducted and reported in accordance with the NCHRP Report No. 350 procedures.

In 2001, a small car crash testing and evaluation program was successfully completed on an 813-mm (32-in.) tall version of the *Midwest Guardrail System* which utilized the standard post spacing (11-12). As such, this paper will only present those research results related to the pickup truck impact condition provided in NCHRP Report No. 350 and that for the standard and reduced post spacing design variations as well as for the guardrail-to-curb barrier combination. Since the small car test results were satisfactory on the full-post spacing guardrail design, MwRSF researchers believe that additional small car testing was deemed unnecessary for the reduced post spacing designs. Prior research has shown successful safety performance for small cars impacting guardrail-to-curb barrier combinations using a 152-mm (6-in.) high asphalt dike (23). When impacted by a small car, this barrier system, like other strong-post W-beam barriers, remained essentially rigid with only modest deflection. In addition, the small car test resulted in no significant potential for occupant risk problems arising from vehicle pocketing, severe wheel snagging on the guardrail posts, no potential for rail rupture, nor vehicular instabilities due to vaulting or climbing the rail (1,24-25). Therefore, the 820-kg (1,808-lb) small car test was also deemed unnecessary for the evaluation of the guardrail-to-curb barrier combination of the *Midwest Guardrail System*.

DESIGN CONSIDERATIONS AND MODIFICATIONS

During the early development of the *Midwest Guardrail System*, LS-DYNA computer simulation modeling was used to investigate how both guardrail-post connection strength and post-soil force affect barrier performance during impacts with higher center-of-mass vehicles (11). Two important conclusions were drawn from that investigation. First, researchers showed that as the guardrail-post connection strength increased from a typical strength to a very strong attachment, there was a reduction in the W-beam guardrail system's ability to capture light trucks. Second, the simulation results also indicated an increased propensity for the light trucks to climb and vault over the barrier system when the guardrail posts were placed in a simulated strong soil versus in a weaker, softer soil.

As a result of these findings, the first three crash tests were performed on a barrier prototype that incorporated an increased length of the post bolt slot equal to 102 mm (4 in.). This longer slot length was used in order to reduce the guardrail-post attachment force, thus decreasing the potential for the W-beam rail to be pulled down during post rotation. The first small car crash test (test no. NPG-1) resulted in an acceptable performance on an original guardrail design that used an increased slot length (11-12). A subsequent pickup truck crash test also showed that the rail would release from the posts in an acceptable manner throughout the impact region. However, this testing also showed a propensity for the rail to release prematurely from the posts near the upstream end of the barrier installation. As a result, the post bolt slot length was reduced back to the standard 64-mm (2 ½-in.) length.

It is widely known that guardrail posts are an integral part of the design of semi-rigid barriers. Post performance greatly influences the guardrail system's ability to safely contain and redirect the impacting vehicle as well as allows for the dissipation of a portion of the vehicle's

kinetic energy through post rotation in the soil. Since post-soil forces are approximately proportional to the square of the post embedment depth, determination of an appropriate post length, post embedment depth, and rail mounting height are all very critical elements to be determined for the new guardrail design. This fact is even more important since the preliminary numerical analysis showed that higher post-soil forces may degrade guardrail performance.

DYNAMIC POST TESTING

Dynamic testing of steel posts placed in soil was conducted in order to evaluate alternative embedment depths as well as to determine the associated force-deflection behaviors. The steel posts were embedded in soil material conforming to AASHTO M147-65 Gradation B specifications (NCHRP Report No. 350 strong soil). The posts used in the *Midwest Guardrail System* consisted of W152x13.4 (W6x9) steel sections. However, the dynamic bogie testing performed for this study utilized W152x23.8 (W6x16) sections for the alternative embedment depths in order to isolate soil failure with only minimal post yielding. Since the W152x23.8 (W6x16) post has a similar flange width and overall depth to that of the W152x13.4 (W6x9) post, it was believed that the posts would exhibit similar post-soil behavior. A 1,014-kg (2,237-lb) rigid-frame bogie vehicle was used to impact the steel guardrail posts at a target speed of 32.2 km/hr (20 mph). An impact head, fabricated from a 203-mm (8-in.) diameter concrete-filled steel pipe and used to strike the posts, was mounted to the front end of the bogie vehicle at a height of 632 mm (24 7/8 in.) above the ground surface. Additional details related to the bogie vehicle and the test setup are provided in the referenced MwRSF research report (13).

A total of ten dynamic bogie tests were performed on the embedded steel posts. Actual impact conditions, post embedment depths, and test results for the tests are provided in Table 1. All steel posts were impacted perpendicular to the front face of the posts or about the post's strong axis of bending, as shown in Figure 1(a). Typical post and soil deformations following two bogie tests are provided in Figure 1(b). Typical force-deflection curves for the steel posts embedded 1,016 mm (40 in.) into the soil are provided in Figure 1(c). Failure of the posts was found to be dependent upon embedment depth. For post embedment depths of 1,016 mm (40 in.) or greater, soil failure was observed with occasions of slight yielding within the post. For post embedment depths of 940 mm (37 in.) or less, the posts were pulled out of the ground after rotating in the soil for some distance. In addition, there were measurable differences in the impact forces observed for the two modes of failure. As a result of these differing impact forces, the amount of energy dissipated also varied. Posts that failed by rotating in the soil dissipated more energy than posts that initially rotated but eventually pulled out of the ground. Additional discussion of the post testing results is provided in the referenced MwRSF research report (13).

Based on the results of the dynamic post testing program, researchers determined that the 1,016-mm (40-in.) embedment depth was a reasonable choice for use in the *Midwest Guardrail System*. This embedment depth, when combined with a 1,829-mm (6-ft) long post and a 787-mm (31-in.) rail top mounting height, provides acceptable post-soil forces and energy dissipation.

One purpose for analyzing the force-deflection curve and energy dissipated during a post test is to quantify post-soil interaction parameters. These parameters are of great interest to those studying vehicular impacts into longitudinal barrier systems, such as the *Midwest Guardrail System*, through the use of dynamic computer simulation modeling. Relevant results from this

study for use in these analytical investigations are the estimated initial post stiffness and the estimated average force for the first 381 to 597 mm (15 to 23.5 in.) of dynamic displacement after the initial slope of the impact force. Over this distance, the guardrail post is typically being separated from the W-beam rail based on observations from full-scale crash tests. Therefore, calculated parameters for estimated average force and estimated initial stiffness are also provided in Table 1.

MIDWEST GUARDRAIL SYSTEM DESIGN DETAILS

Design A – Standard 1,905-mm Post Spacing

The first test installation (Design A) consisted of 55.25 m (181 ft-3 in.) of standard 2.66-mm (12-gauge) thick W-beam guardrail supported by steel posts, as shown in Figure 2. Anchorage systems similar to those used on tangent guardrail terminals were utilized on both the upstream and downstream ends of the guardrail system. A photograph of the test installation is shown in Figure 2.

The entire system was constructed with twenty-nine guardrail posts. Post nos. 3 through 27 were galvanized ASTM A36 steel W152x13.4 (W6x9) sections measuring 1,829-mm (6-ft) long. Post nos. 1, 2, 28, and 29 were timber posts measuring 140-mm wide x 190-mm deep x 1,080-mm long (5 ½-in. x 7 ½-in. x 42 ½-in.) and were placed in 1,829-mm (6-ft) long steel foundation tubes. The timber posts and foundation tubes were part of anchor systems designed to replicate the capacity of a tangent guardrail terminal.

Post nos. 1 through 29 were spaced 1,905 mm (75 in.) on center with a soil embedment depth of 1,019 mm (40 in.), as shown in Figure 2. The posts were placed in a compacted course, crushed limestone material that met Grading B of AASHTO M147-65 (1990) as found in NCHRP Report No. 350. For post nos. 3 through 27, 152-mm wide x 305-mm deep x 356-mm long (6-in. x 12-in. x 14-in.), routed wood spacer blockouts were used to block the rail away from the front face of the steel posts.

Standard 2.66-mm (12-gauge) thick W-beam rails with additional post bolt slots at half post spacing intervals were placed between post nos. 1 and 29, as shown in Figure 2. The nominal top mounting height of the W-beam rail was 787 mm (31 in.) with a 632-mm (24 ⅞-in.) center height. The rail splices have been moved to the center of the span location, as shown in Figure 2. All lap-splice connections between the rail sections were configured to reduce vehicle snag at the splice during the crash test.

Design B – Reduced 476-mm Post Spacing

The second test installation (Design B) was identical to the first system (Design A) except that the original guardrail system was stiffened through the use of a reduced post spacing. Post nos. 9 through 11 and 51 through 53 were spaced 952.5 mm (37 ½ in.) on center while post nos. 11 through 51 were spaced 476.25 mm (18 ¾ in.) on center. The standard 2.66-mm (12-gauge) thick W-beam rails located between post nos. 9 and 53 were modified to include additional post bolt slots at half- and quarter-post spacing intervals, as shown in Figure 3(a).

Design C – Standard 1,905-mm Post Spacing with 152-mm Type B Curb

The third test installation (Design C) was identical to the first system (Design A) except that the guardrail system was installed over a 152-mm (6-in.) tall, AASHTO Type “B” concrete curb. A 152-mm (6-in.) versus a 102-mm (4-in.) high concrete curb was selected for testing since increased hydraulic drainage is often required at the roadway edge, and the taller curb is believed to provide a “worst case” impact scenario for the guardrail-to-curb barrier combination. Therefore, if the test results are found to be satisfactory, then shorter curb heights would also be acceptable and not require additional testing. The curb located beneath the W-beam guardrail was 19.05-m (62-ft, 6-in.) long, spanning between post nos. 10 and 20. The curb was constructed such that the center of the curb face was placed 152 mm (6 in.) in front of the front face of the guardrail, as shown in Figure 3(b). It should be noted that the top mounting height of the guardrail remained at 787 mm (31 in.), which was measured from the gutter line to the top of the W-beam rail.

FULL-SCALE VEHICLE CRASH TESTING

Crash Test No. NPG-4 – Design A

For test no. NPG-4, a 1,986-kg (4,378-lb) pickup truck impacted the *Midwest Guardrail System* with standard post spacing (Design A) at a speed of 98.1 km/hr (61.0 mph) and at an angle of 25.6 degrees. Initial impact occurred 4,839 mm (190 ½ in.) upstream from the centerline of the splice between post nos. 14 and 15, as shown in Figure 4. At 0.396 sec after impact, the vehicle became parallel to the guardrail with a resultant velocity of 61.2 km/hr (38.0 mph). The vehicle was safely redirected in a very stable manner with very little roll or pitch. At 0.597 sec, the vehicle exited the guardrail at a trajectory angle of 19.3 degrees and at a resultant velocity of 55.1 km/hr (34.2 mph). Exterior vehicle damage was minimal, consisting of minor right-front corner deformations, and there was no observable occupant compartment deformations. Damage to the barrier was moderate, consisting mostly of deformed W-beam and guardrail posts, contact marks on a guardrail section, and disengaged wooden blockouts. Maximum dynamic barrier deflection was 1,094 mm (43 in.) at the midspan between post nos. 14 and 15, and the system’s working width was 1,260 mm (50 in.). The vehicle and barrier damage are shown in Figure 5(a). A summary of the test results and the sequential photographs are shown in Figure 4. Test no. NPG-4 conducted on Design A was determined to be acceptable according to the NCHRP Report No. 350 safety performance criteria.

Crash Test No. NPG-6 – Design B

For test no. NPG-6, a 2,001-kg (4,411-lb) pickup truck impacted the *Midwest Guardrail System* with reduced post spacing (Design B) at a speed of 96.8 km/hr (60.2 mph) and at an angle of 25.6 degrees. Initial impact occurred 2,946 mm (116 in.) upstream from the centerline of post no. 29, as shown in Figure 6. At 0.297 sec after impact, the vehicle became parallel to the guardrail with a resultant velocity of 59.5 km/hr (37.0 mph). The vehicle was safely redirected in a very stable manner with very little roll or pitch. At 0.491 sec, the vehicle exited the guardrail at a

trajectory angle of 12.9 degrees and at a resultant velocity of 59.5 km/hr (37.0 mph). Exterior vehicle damage was moderate, consisting of right-front corner deformations. Minimal interior occupant compartment deformations occurred with only slight deformations of the floorboard. Damage to the barrier was moderate, consisting mostly of deformed W-beam and guardrail posts, contact marks on a guardrail section, and disengaged wooden blockouts. Maximum dynamic barrier deflection was 447 mm (18 in.) at the centerline of post no. 27, and the system's working width was 931 mm (37 in.). The vehicle and barrier damage are shown in Figure 5(b). A summary of the test results and the sequential photographs are shown in Figure 6. Test no. NPG-6 conducted on Design B was determined to be acceptable according to the NCHRP Report No. 350 safety performance criteria.

Crash Test No. NPG-5 – Design C

For test no. NPG-5, a 1,988-kg (4,383 lb) pickup truck impacted the *Midwest Guardrail System* installed over a concrete curb (Design C) at a speed of 96.6 km/hr (60.0 mph) and at an angle of 25.8 degrees. Initial impact occurred 4,547 mm (179 in.) upstream from the centerline of the splice between post nos. 14 and 15, as shown in Figure 7. At 0.518 sec after impact, the vehicle became parallel to the guardrail with a resultant velocity of 52.3 km/hr (32.5 mph). Prior to the vehicle exiting the system, the vehicle encountered moderate roll away from the rail and moderate pitching toward its left-front corner. At 0.718 sec, the vehicle exited the guardrail at an orientation angle of 6.7 degrees and at a resultant velocity of 48.0 km/hr (29.8 mph). Exterior vehicle damage was moderate, consisting of right-front corner deformations, and there was no observable occupant compartment deformations. Damage to the barrier was moderate, consisting mostly of deformed W-beam and guardrail posts, an uprooted guardrail post, contact marks on a guardrail section, and disengaged wooden blockouts. Maximum dynamic barrier deflection was 1,024 mm (40 in.) at the midspan between post nos. 14 and 15, and the system's working width was 1,625 mm (64 in.). The vehicle and barrier damage are shown in Figure 5(c). A summary of the test results and the sequential photographs are shown in Figure 7. Test no. NPG-5 conducted on Design C was determined to be acceptable according to the NCHRP Report No. 350 safety performance criteria.

COMPUTER SIMULATION MODELING

Non-linear, 2-dimensional (2-D) computer simulation modeling with BARRIER VII (28) was used to analyze and predict the dynamic performance of the *Midwest Guardrail System*. This impact analysis included a calibration and validation of the pickup truck crash tests performed on both the standard (test no. NPG-4) and reduced post spacing (test no. NPG-6) designs. For the validation effort, several simulations were performed at the impact conditions of the two crash tests in order to calibrate selected BARRIER VII input parameters. For the posts, initial parameters were obtained from the dynamic post testing, as shown in Figure 8(a). Other parameters worth noting include, post failure displacement based on guardrail release, vehicle-to-barrier dynamic coefficient of friction, and yaw mass moment of inertia for the pickup truck. The data acquired from the overhead high-speed film, onboard vehicle accelerometers, and speed traps were used to calibrate vehicle simulations to the two physical tests.

The calibration effort began with the development of a finite element model for the standard post spacing design (Design A). Using a parametric technique, initial simulations showed a need to tune input parameters for posts located both in the impact region as well as at the ends. It was also necessary to adjust the vehicle to rail friction coefficient and the vehicle's yaw mass moment of inertia in order to more accurately predict vehicle behavior at the parallel and exit conditions. The final validated BARRIER VII input parameters for test no. NPG-4 are provided in Figure 8(a). A graphical comparison of the simulated and actual barrier displacements for test no. NPG-4 are provided in Figure 8(b). As shown in Figure 8(b), BARRIER VII had some difficulty fully reproducing the guardrail shape near the upstream end of the deformed region. However, it should be noted that during the actual test, the vehicle's rear end pitched up and protruded over the rail during redirection. Since BARRIER VII is limited to planar motion, it is unable to reproduce roll and pitch angular motions. Therefore, it would calculate vehicle tail slap into the barrier, thus potentially increasing the predicted barrier displacements in this region. Tabulated validation results for vehicle behavior, barrier displacements, and working width for NPG-4 are shown in Figure 8(c). From this effort, researchers determined that the final simulation accurately predicted barrier performance and vehicle behavior for the standard post spacing configuration.

Once the calibration effort was completed for test no. NPG-4, simulations commenced on the reduced post spacing design (Design B) which was evaluated by test no. NPG-6. Using the same parametric evaluation, researchers determined that the final post properties used in the NPG-4 validation effort were appropriate for the NPG-6 simulations as well. However, it was necessary to increase the vehicle to rail friction coefficient from 0.400 to 0.475 in order to more accurately predict vehicle behavior. Initially, it may seem unreasonable to adjust the vehicle to barrier friction coefficient since it should be the same for comparable guardrail tests. However, one must understand that wheel contact and snag on additional posts effectively caused additional vehicle drag and energy loss in the actual system that BARRIER VII cannot predict. Therefore, adjustment of the effective coefficient of friction was deemed appropriate. A graphical comparison of the simulated and actual barrier displacements for test no. NPG-6 are provided in Figure 8(b). Tabulated validation results for vehicle behavior, barrier displacements, and working width for NPG-6 are shown in Figure 8(c). Once again, researchers determined that the final simulation accurately predicted barrier performance and vehicle behavior for the reduced post spacing configuration.

In addition to the comparisons shown previously, researchers chose to compare the longitudinal and lateral accelerations as well as changes in the vehicle's velocity after the final NPG-4 and 6 validation runs were completed. Therefore, the same SAE filtering procedures outlined in NCHRP Report No. 350 were applied to the simulation data in order to obtain CFC 60 (100 Hz) vehicle accelerations and CFC 180 (300 Hz) changes in velocity and on data acquired with the same sample rate. Figure 9 shows the results of this comparison. For the NPG-4 comparison, BARRIER VII generally predicted the acceleration trends but could not predict peaks. While peak accelerations could not be reproduced, changes in vehicle velocity were shown to be reasonably accurate through approximately 300 msec or close to a vehicle parallel condition. For the NPG-6 comparison, BARRIER VII more accurately predicted the acceleration trends than observed in the NPG-4 comparisons. However, it was once again incapable of

predicting peak accelerations. More importantly, though, BARRIER VII was very accurate in predicting vehicle changes in velocity for the stiffened barrier configuration.

For this study, BARRIER VII modeling was also used to predict overall guardrail performance and working width for the standard-, half-, and quarter-post designs at the TL-3 impact conditions. These results would later be used to provide guidance for determining appropriate guardrail placement practices. Each post configuration was evaluated using an analysis technique to determine the Critical Impact Point (CIP) for the three designs. As such, simulations were performed on each design and at incremental distances along the rail in order to determine the predicted maximum dynamic rail deflection as well as an estimate for the maximum working width. The working width for a given barrier design should be used to determine the appropriate guardrail placement in front of and for shielding a rigid hazard. Based on a CIP analysis for the three systems, a maximum dynamic rail deflection of 1,059 mm (41.7 in.), 705 mm (27.8 in.), and 447 mm (17.6 in.), was observed for the standard-, half-, and quarter-post spacing designs, respectively. Similarly, each barrier's working width, based on engine hood extend over the rail, was found to be 1,230 mm (48.4 in.), 976 mm (38.4 in.), and 815 mm (32.1 in.), for the standard-, half-, and quarter-post spacing designs, respectively. In addition, each barrier's working width, based on the lateral position of the back of the post, was found to be 1,391 mm (54.8 in.), 1,094 mm (43.1 in.), and 871 mm (34.3 in.), for the standard-, half-, and quarter-post spacing designs, respectively. Although the working width was governed by post displacement for the standard post spacing design, it is unlikely that the post would remain attached to the rail for that displacement. Therefore, if governed by intrusion of the corner of the engine hood, the working width would be 1,230 mm (48.4 in.).

GUARDRAIL PLACEMENT GUIDELINES

As previously discussed, one research objective was to determine guardrail placement guidelines for shielding roadside obstacles using the standard *Midwest Guardrail System* as well as the two stiffened variations. Based on an analysis of the test and simulation results, the minimum recommended distances that the *Midwest Guardrail System* should be placed away from a rigid hazard are 1.25 m (49 in.), 1.12 m (44 in.), and 0.90 m (35 in.), for the standard-, half-, and quarter post-spacing designs, respectively, as measured from the front face of the W-beam rail to the front face of the hazard.

SUMMARY, CONCLUSIONS, AND RECOMMENDATIONS

Development of the *Midwest Guardrail System* was continued in order to provide increased safety for high center-of-mass vehicles, provide improved height tolerances, and reduce the potential for W-beam rupture. The barrier system has been shown to perform well for small car impacts when mounted as high as 813 mm (32 in.) and has performed very well during light truck impacts for the standard top mounting height of 787 mm (31 in.) for three different placement situations. The standard *Midwest Guardrail System* design performed very well for the standard configuration with a 1905-mm (6-ft 3-in.) post configuration, for a quarter-post spacing of 476 mm (1 ft-6³/₄ in.), and when placed 152 mm (6 in.) behind a 152-mm (6-in.) high concrete curb. In each test, the *Midwest Guardrail System* safely redirected the ³/₄-ton truck in a

very stable manner. These test results clearly indicate that the new barrier will reduce the high rollover rates currently associated with light truck impacts on standard guardrail designs. Further, in every pickup truck test conducted thus far on the *Midwest Guardrail System*, the test vehicle was brought to a safe stop immediately adjacent to the barrier. Thus, the *Midwest Guardrail System* will provide improved safety for light truck impacts, not only by reducing the propensity for rollover during high speed/high angle impacts but also by keeping the impacting vehicles close to the guardrail, thereby eliminating the potential for secondary impacts with other vehicles.

A combination of full-scale crash testing, dynamic component testing, and computer simulation was also used to identify maximum barrier deflections and working widths for the *Midwest Guardrail System* when installed with standard-, half-, and quarter-post spacings. As previously provided, these guidelines should allow designers to utilize the new barrier with confidence, even when fixed hazards are located very near the face of the guardrail.

Unfortunately, two problems remain to be resolved before the *Midwest Guardrail System* can be fully implemented. No guardrail system can be widely implemented without an acceptable method for terminating the barrier. Therefore, existing guardrail terminal designs must be adapted to the new mounting height before the *Midwest Guardrail System* can be utilized. Higher guardrail mounting heights may allow small cars to penetrate under the impact heads and buffer nose sections utilized on the ends of W-beam guardrail. Further, both the increased height and the associated reduction in post embedment depth has been shown to increase the loading on guardrail terminal anchors. Therefore, the revised designs must be retested at the beginning of the length-of-need with a $\frac{3}{4}$ -ton pickup truck. Finally, the raised height and reduced embedment depth and anchorage may also create problems for small cars impacting the barrier upstream of the beginning of length-of-need. Hence, it is strongly recommended that manufacturers conduct three full-scale crash tests on the currently approved guardrail terminal systems attached to the *Midwest Guardrail System* before the design can be implemented widely.

One of the most common applications for W-beam guardrails is on the approach to bridge railings. Hence, another barrier to implementation of the *Midwest Guardrail System* is the development of acceptable guardrail/bridge rail transitions. Most guardrail/bridge rail transition designs incorporate three beam rail elements with a top height of 787 mm (31 in.). These designs incorporate a three beam to W-beam transition element that allows the center of the W-beam and three beam rails to be mounted at the same height. In order to attach the *Midwest Guardrail System* to these transition systems, a revised three beam that flares downward must be successfully tested. This effort is currently underway, and it is hoped that the testing will be completed before the beginning of the 2004 construction season.

In summary, the *Midwest Guardrail System* development is nearing completion. All testing conducted to date indicates that by reducing the propensity for causing rollovers, the new barrier will offer greatly improved protection for occupants of light trucks. The new barrier was developed with funding from the Midwest States' Pooled Fund program and is entirely non-proprietary. Highway agencies are strongly encouraged to consider adopting the new barrier system as soon as FHWA acceptance letters are issued for the guardrail system as well as the modified terminals and transitions.

DISCLAIMER

The contents of this paper reflect the views of the authors who are responsible for the facts and accuracy of the data presented herein. The contents do not necessarily reflect the official views or policies of the State Highway Departments participating in the Midwest States' Regional Pooled Fund Research Program nor the Federal Highway Administration. This paper does not constitute a standard, specification, or regulation.

ACKNOWLEDGEMENTS

The authors wish to acknowledge several sources that made contributions to this project: the Midwest States' Pooled Fund Program funded by the State Department of Transportation in Connecticut, Iowa, Kansas, Minnesota, Missouri, Montana, Nebraska, Ohio, South Dakota, Texas, and Wisconsin for sponsoring this project and the MwRSF personnel for constructing the barriers and conducting the crash tests.

REFERENCES

1. Buth, C.E., Campise, W.L., Griffin, III, L.I., Love, M.L., and Sicking, D.L., *Performance Limits of Longitudinal Barrier Systems - Volume I - Summary Report*, Report No. FHWA/RD-86/153, Submitted to the Office of Safety and Traffic Operations, Federal Highway Administration, Performed by Texas Transportation Institute, May 1986.
2. Ross, H.E., Sicking, D.L., Zimmer, R.A., and Michie, J.D., *Recommended Procedures for the Safety Performance Evaluation of Highway Features*, National Cooperative Research Program (NCHRP) Report No. 350, Transportation Research Board, Washington, D.C., 1993.
3. Mak, K.K., Bligh, R.P., and Menges, W.L., *Testing of State Roadside Safety Systems - Volume XI: Appendix J - Crash Testing and Evaluations of Existing Guardrail Systems*, Draft Final Report, Research Study No. RF 471470, Sponsored by Office of Safety and Traffic Operations R&D, Federal Highway Administration, Performed by Texas Transportation Institute, Texas A&M University, College Station, Texas, December 1995.
4. Buth, C.E., Menges, W.L., Ivey, D.L., and Williams, W.F., *W-Beam Guardrail*, Paper No. 990871, Paper Presented at the 78th Annual Meeting of the Transportation Research Board, Washington, D.C., January 1999.
5. Polivka, K.A., Sicking, D.L., Rohde, J.R., Faller, R.K., *Crash Testing of Michigan's Type B (W-Beam) Guardrail System*, Final Report to the Michigan Department of Transportation, Transportation Research Report No. TRP-03-90-99, Midwest Roadside Safety Facility, University of Nebraska-Lincoln, Lincoln, Nebraska, November 10, 1999.
6. Polivka, K.A., Sicking, D.L., Rohde, J.R., Faller, R.K., and Holloway, J.C., *Crash Testing of Michigan's Type B (W-Beam) Guardrail System - Phase II*, Final Report to the Michigan Department of Transportation, Transportation Research Report No. TRP-03-104-00, Midwest Roadside Safety Facility, University of Nebraska-Lincoln, Lincoln, Nebraska, December 13, 2000.
7. Bligh, R.P., Menges, W.L., and Butler, B.G., *Evaluation of a Modified Steel Post W-Beam Guardrail System*, Report No. TX-98/3963-S, Sponsored by the Texas Department of Transportation, Performed by Texas Transportation Institute, Texas A&M University, College Station, Texas, November 1997.
8. Bligh, R.P., and Menges, W.L., *Testing and Evaluation of a Modified Steel Post W-Beam Guardrail System with Recycled Polyethylene Blockouts*, Report No. 400001-MPT, Sponsored by Mondo Polymer Technologies, Performed by Texas Transportation Institute, Texas A&M University, College Station, Texas, February 1997.

9. Bullard, D.L., Jr., Menges, W.L., and Alberson, D.C., *NCHRP Report 350 Compliance Test 3-11 of the Modified G4(1S) Guardrail with Timber Blockouts*, Report No. FHWA-RD-96-175, Sponsored by the Office of Safety and Traffic Operations R&D, Federal Highway Administration, Performed by Texas Transportation Institute, Texas A&M University, College Station, Texas, September 1996.
10. Bligh, R.P. and Bullard, D.L., *Crash Testing and Evaluation of Round, Wood Post, W-Beam Guardrail System*, Research Study No. 405391, Sponsored by Arnold Forest Products, Performed by Texas Transportation Institute, Texas A&M University, College Station, Texas, October 1995.
11. Sicking, D.L., Reid, J.D., and Rohde, J.R., *Development of the Midwest Guardrail System*, Paper No. 02-3157, Transportation Research Record No. 1797, Transportation Research Board, Washington, D.C., 2002.
12. Polivka, K.A., Faller, R.K., Sicking, D.L., Reid, J.D., Rohde, J.R., Holloway, J.C., Bielenberg, R.W., and Kuipers, B.D., *Development of the Midwest Guardrail System for Standard and Reduced Post Spacing and in Combination with Curbs*, MwRSF Research Report No. TRP-03-139-03, Draft Report to the Midwest States Regional Pooled Fund Program, Midwest Roadside Safety Facility, University of Nebraska-Lincoln, Lincoln, Nebraska, Report in Progress.
13. Kuipers, B.D. and Reid, J.D., *Testing of W152x23.8 (W6x16) Steel Posts - Soil Embedment Depth Study for the Midwest Guardrail System (Non-Proprietary Guardrail System)*, MwRSF Research Report No. TRP-03-136-03, Final Report to the Midwest States' Regional Pooled Fund Program, Midwest Roadside Safety Facility, University of Nebraska-Lincoln, Lincoln, Nebraska, June 12, 2003.
14. Hallquist, J.O., *LS-DYNA Keyword User's Manual - Version 960*, Livermore Software Technology Corporation (LSTC), Livermore, California, 2001.
15. Holloway, J.C., Bierman, M.G., Pfeifer, B.G., Rosson, B.T., and Sicking, D.L., *Performance Evaluation of KDOT W-Beam Systems - Volume I: Full-Scale Crash Testing*, Final Report to the Midwest State's Regional Pooled Fund Program, Transportation Research Report No. TRP-03-39-96, Project No. SPR-3(17), Midwest Roadside Safety Facility, University of Nebraska-Lincoln, Lincoln, Nebraska, May 1996.
16. Holloway, J.C., Bierman, M.G., Pfeifer, B.G., Rosson, B.T., and Sicking, D.L., *Performance Evaluation of KDOT W-Beam Systems - Volume II: Component Testing and Computer Simulation*, Final Report to the Midwest State's Regional Pooled Fund Program, Transportation Research Report No. TRP-03-39-96, Project No. SPR-3(17), Midwest Roadside Safety Facility, University of Nebraska-Lincoln, Lincoln, Nebraska, May 1996.

17. Rosson, B.T., Bierman, M.G., and Rohde, J.R., *Assessment of Guardrail-Strengthening Techniques*, Transportation Research Record No. 1528, Transportation Research Board, Washington, D.C., 1996.
18. *Determination of Strengthened Guardrail Deflection*, Memorandum, Federal Highway Administration, U.S. Department of Transportation, May 18, 1989.
19. *Roadside Design Guide*, Chapter 5 Roadside Barriers, Section 5.5.2 Barrier Deflection Characteristics, American Association of State Highway and Transportation Officials (AASHTO), Washington D.C., 2002.
20. Bullard, D.L., Jr. and Menges, W.L., *NCHRP Report 350 Test 3-11 of the G4(2W) Strong Post W-Beam Guardrail with 100-mm High Asphaltic Curb*, Report Nos. FHWA-RD-00 and 404202-1, Sponsored by the Federal Highway Administration, Performed by Texas Transportation Institute, Texas A&M University, College Station, Texas, June 2000.
21. Polivka, K.A., Faller, R.K., Sicking, D.L., Rohde, J.R., Reid, J.D., and Holloway, J.C., *Guardrail and Guardrail Terminals Installed Over Curbs*, Final Report to the Midwest State's Regional Pooled Fund Program, Transportation Research Report No. TRP-03-83-99, Project No. SPR-3(017)-Year 8, Midwest Roadside Safety Facility, University of Nebraska-Lincoln, Lincoln, Nebraska, March 21, 2000.
22. Polivka, K.A., Faller, R.K., Sicking, D.L., Rohde, J.R., Reid, J.D., and Holloway, J.C., *Guardrail and Guardrail Terminals Installed Over Curbs - Phase II*, Final Report to the Midwest State's Regional Pooled Fund Program, Transportation Research Report No. TRP-03-105-00, Project No. SPR-3(017)-Year 10, Midwest Roadside Safety Facility, University of Nebraska-Lincoln, Lincoln, Nebraska, November 5, 2001.
23. Stout, D., Hughes, W., and McGee, H., *Traffic Barriers on Curves, Curbs, and Slopes*, Report No. FHWA-RD-93-082, Final Report to Office of Safety and Traffic Operations R&D, Federal Highway Administration, Performed by ENSCO, Inc., Springfield, Virginia, October 1993.
24. Ivy, D.L., Robertson, R., and Buth, C.E., *Test and Evaluation of W-Beam and Thrie-Beam Guardrails*, Report No. FHWA/RD-82/071, Submitted to the Office of Research, Federal Highway Administration, Performed by Texas Transportation Institute, March 1986.
25. Ross, Jr., H.E., Perera, H.S., Sicking, D.L., and Bligh, R.P., *Roadside Safety Design for Small Vehicles*, National Cooperative Highway Research Program (NCHRP) Report No. 318, Transportation Research Board, Washington, D.C., May 1989.
26. *Vehicle Damage Scale for Traffic Investigators*, Second Edition, Technical Bulletin No. 1, Traffic Accident Data (TAD) Project, National Safety Council, Chicago, Illinois, 1971.

27. *Collision Deformation Classification - Recommended Practice J224 March 1980*, Handbook Volume 4, Society of Automotive Engineers (SAE), Warrendale, Pennsylvania, 1985.
28. Powell, G.H., *BARRIER VII: A Computer Program For Evaluation of Automobile Barrier Systems*, Prepared for: Federal Highway Administration, Report No. FHWA RD-73-51, April 1973.

LIST OF FIGURES

FIGURE 1 (a) Typical Posts Installed for Bogie Testing, (b) Typical Post Deformation in Soil, (c) Force-Displacement Curves for 1,016-mm Embedment Depth [1 in. = 25.4 mm].

FIGURE 2 *Midwest Guardrail System* – Standard Post Spacing Design Details (Design A) [1 in. = 25.4 mm].

FIGURE 3 *Midwest Guardrail System* for Special Applications: (a) Quarter-Post Spacing (Design B), (b) Standard Post Spacing with AASHTO Type B Curb (Design C) [1 in. = 25.4 mm].

FIGURE 4 Summary of Test Results and Sequential Photographs, Test No. NPG-4. [1 in. = 25.4 mm]

FIGURE 5 Barrier and Vehicle Damage: (a) Test No. NPG-4, (b) Test No. NPG-6, (c) Test No. NPG-5.

FIGURE 6 Summary of Test Results and Sequential Photographs, Test No. NPG-6 [1 in. = 25.4 mm].

FIGURE 7 Summary of Test Results and Sequential Photographs, Test No. NPG-5 [1 in. = 25.4 mm].

FIGURE 8 Barrier VII Calibration and Validation: (a) Selected Simulation Input Parameters, (b) Graphical Comparison of Barrier Displacements, (c) Tabulated Results of Actual Test Data and Barrier VII Simulation.

FIGURE 9 Comparison of Test and Simulation Results: (a) Longitudinal Direction [NPG-4], (b) Lateral Direction [NPG-4], (c) Longitudinal Direction [NPG-6], and (d) Lateral Direction [NPG-6].

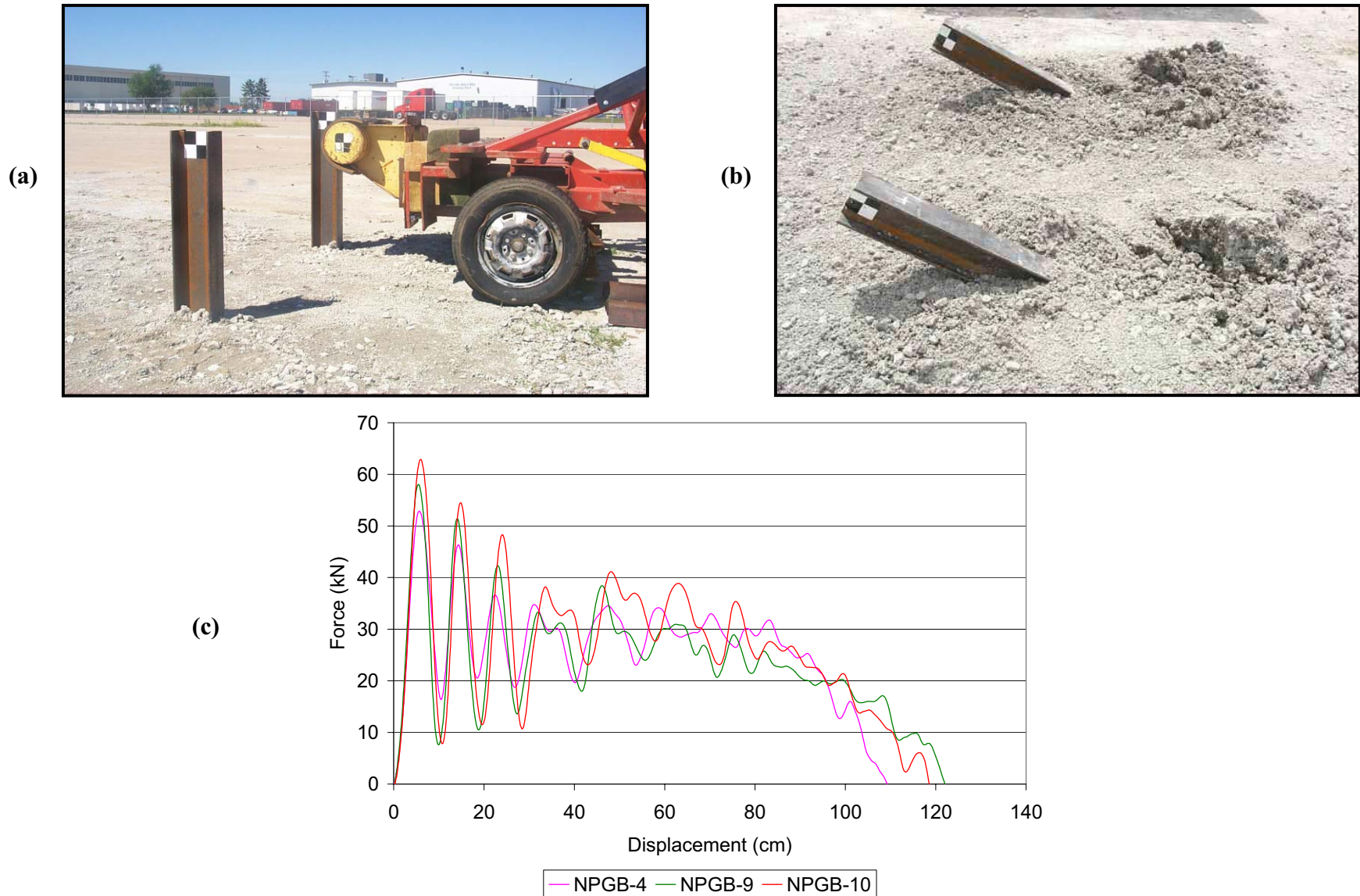

FIGURE 1 (a) Typical Posts Installed for Bogie Testing, (b) Typical Post-Soil Behavior, (c) Force-Displacement Curves for 1,016-mm Embedment Depth [1 in. = 25.4 mm].

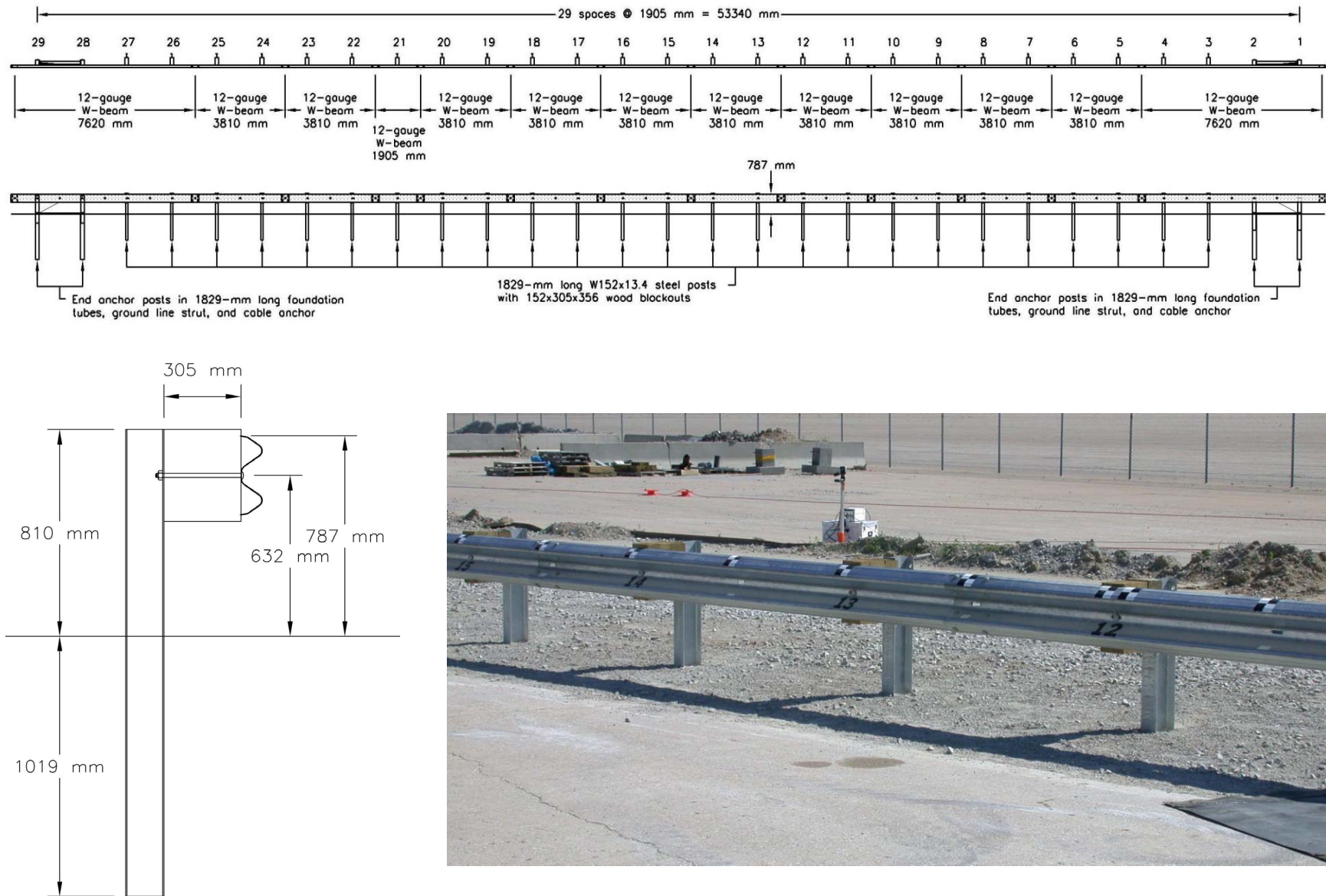
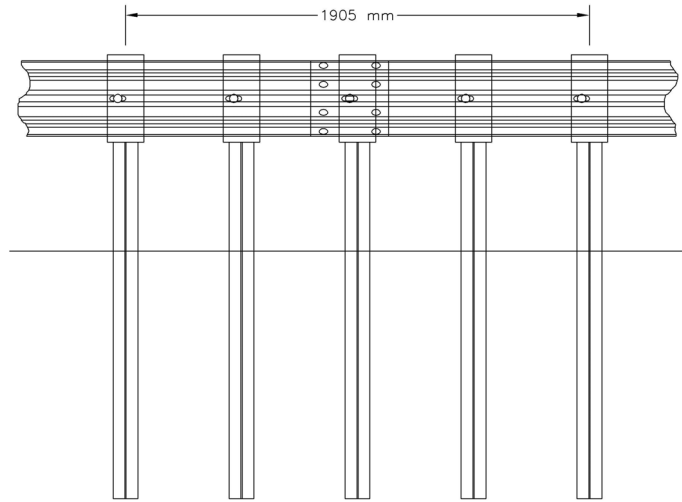
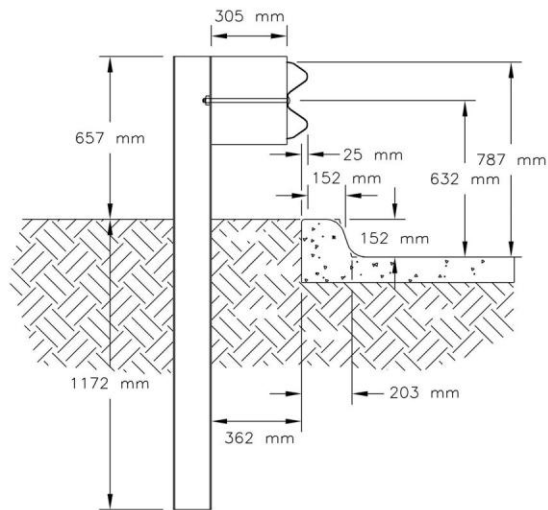

FIGURE 2 Midwest Guardrail System - Standard Post Spacing Design Details (Design A) [1 in. = 25.4 mm].



(a)



(b)

FIGURE 3 Midwest Guardrail System for Special Applications: (a) Quarter-Post Spacing (Design B), (b) Standard Post Spacing With AASHTO Type B Curb (Design C) [1 in. = 25.4 mm].

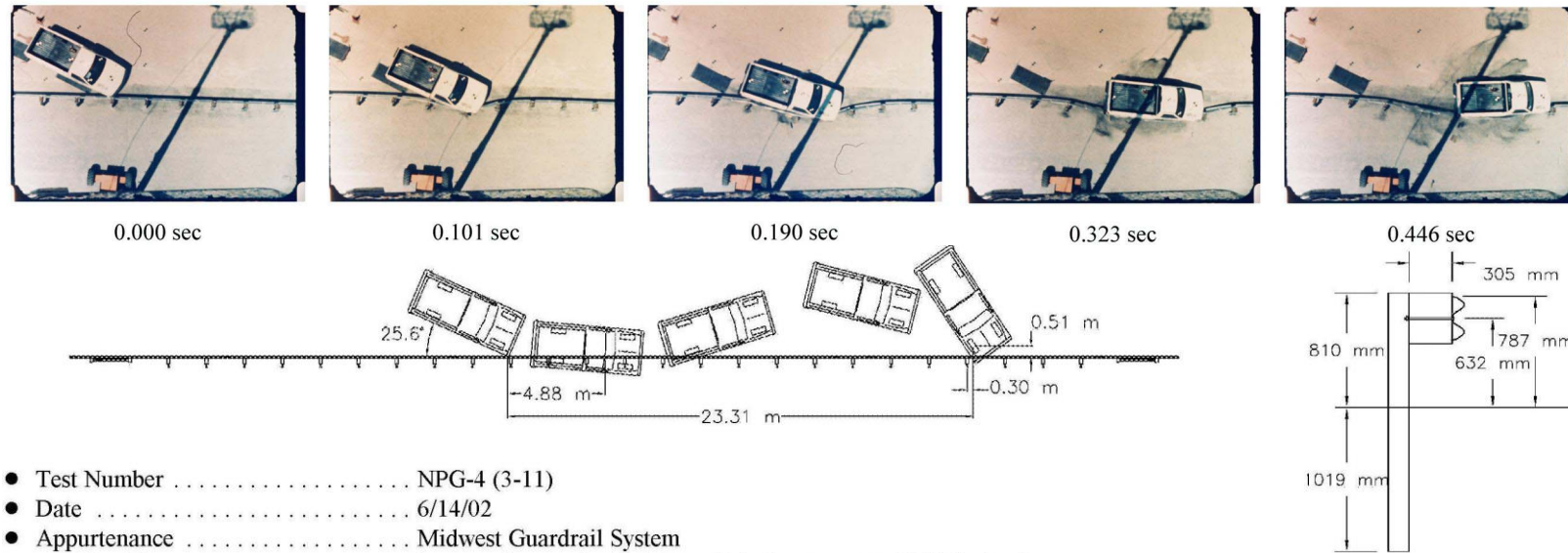

- Test Number NPG-4 (3-11)
- Date 6/14/02
- Appurtenance Midwest Guardrail System
 - Key Elements increased mounting height and blockout depth, and mid-span splices
- Total Length 55.25 m
- Steel W-beam
 - Thickness 2.66 mm
 - Top Mounting Height 787 mm
- Steel Posts
 - Post Nos. 3 - 27 W152 x 13.4 by 1,829-mm long
 - Spacing 1,905 mm
- Wood Posts
 - Post Nos. 1 -2, 28 - 29 (BCT) 140 mm x 190 mm by 1,080-mm long
- Wood Spacer Blocks
 - Post Nos. 3 - 27 152 mm x 305 mm by 356-mm long
- Soil Type Grading B - AASHTO M 147-65 (1990)
- Vehicle Model 1995 GMC C2500 pickup truck
 - Curb 1,913 kg
 - Test Inertial 1,986 kg
 - Gross Static 1,986 kg
- Vehicle Speed
 - Impact 98.1 km/hr
 - Exit (resultant) 55.1 km/hr
- Vehicle Angle
 - Impact (trajectory) 25.6 deg
 - Exit (trajectory) 19.3 deg
- Vehicle Stability Satisfactory
- Occupant Ridedown Deceleration (10 msec avg.)
 - Longitudinal 9.50 g's < 20 g's
 - Lateral (not required) 6.94 g's
- Occupant Impact Velocity
 - Longitudinal 5.58 m/s < 12 m/s
 - Lateral (not required) 3.89 m/s
- Vehicle Damage Minimal
 - TAD²⁶ 1-RFQ-4
 - SAE²⁷ 01RFEW5
- Vehicle Stopping Distance 23.31 m downstream
 - 0.51 m left
- Test Article Damage Moderate
- Maximum Deflection
 - Permanent Set 652 mm
 - Dynamic 1,094 mm
- Working Width 1,260 mm

FIGURE 4 Summary of Test Results and Sequential Photographs, Test No. NPG-4 [1 in. = 25.4 mm].



(a)



(b)



(c)

FIGURE 5 Barrier and Vehicle Damage – (a) Test No. NPG-4, (b) Test No. NPG-6, (c) Test No. NPG-5.

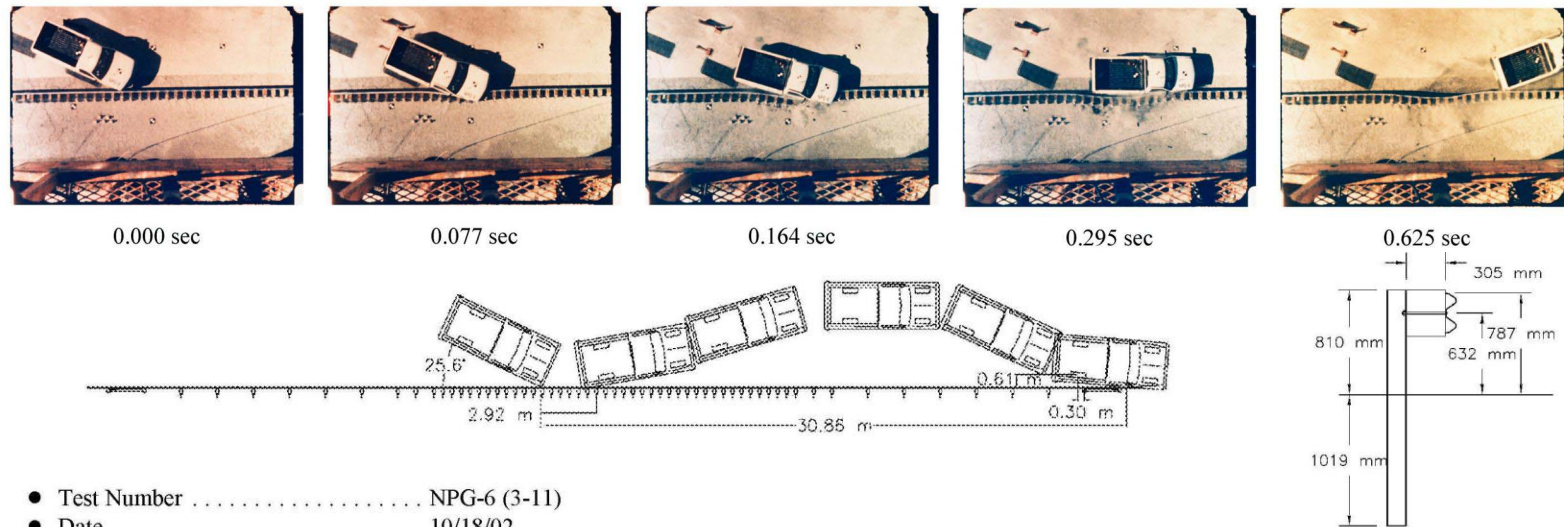

- Test Number NPG-6 (3-11)
- Date 10/18/02
- Appurtenance Midwest Guardrail System with reduced post spacing
 - Key Elements reduced post spacing, increased mounting height and blockout depth
- Total Length 55.25 m
- Steel W-beam
 - Thickness 2.66 mm
 - Top Mounting Height 787 mm
- Steel Posts
 - Post Nos. 3 - 59 W152 x 13.4 by 1,829-mm long
- Steel Post Spacing
 - Post Nos. 3 - 8, 54 - 59 1,905 mm
 - Post Nos. 9 - 10, 52 - 53 953 mm
 - Post Nos. 11 - 51 476 mm
- Wood Posts
 - Post Nos. 1 - 2, 60 - 61 (BCT) 140 mm x 190 mm by 1,080-mm long
- Wood Spacer Blocks
 - Post Nos. 3 - 59 152 mm x 305 mm by 356-mm long
- Soil Type Grading B - AASHTO M 147-65 (1990)
- Vehicle Model 1997 GMC C2500 pickup truck
 - Curb 1,971 kg
 - Test Inertial 2,001 kg
 - Gross Static 2,001 kg
- Vehicle Speed
 - Impact 96.8 km/hr
 - Exit (resultant) 59.5 km/hr
- Vehicle Angle
 - Impact (trajectory) 25.6 deg
 - Exit (trajectory) 12.9 deg
- Vehicle Stability Satisfactory
- Occupant Ridedown Deceleration (10 msec avg.)
 - Longitudinal 10.67 g's < 20 g's
 - Lateral (not required) 8.97 g's
- Occupant Impact Velocity
 - Longitudinal 7.62 m/s < 12 m/s
 - Lateral (not required) 5.61 m/s
- Vehicle Damage Moderate
 - TAD²⁶ 1-RFQ-5
 - SAE²⁷ 01RYEW7
- Vehicle Stopping Distance 30.86 m downstream
 - 0.0 m left
- Test Article Damage Moderate
- Maximum Deflection
 - Permanent Set 305 mm
 - Dynamic 447 mm
- Working Width 931 mm

FIGURE 6 Summary of Test Results and Sequential Photographs, Test No. NPG-6 [1 in. = 25.4 mm].

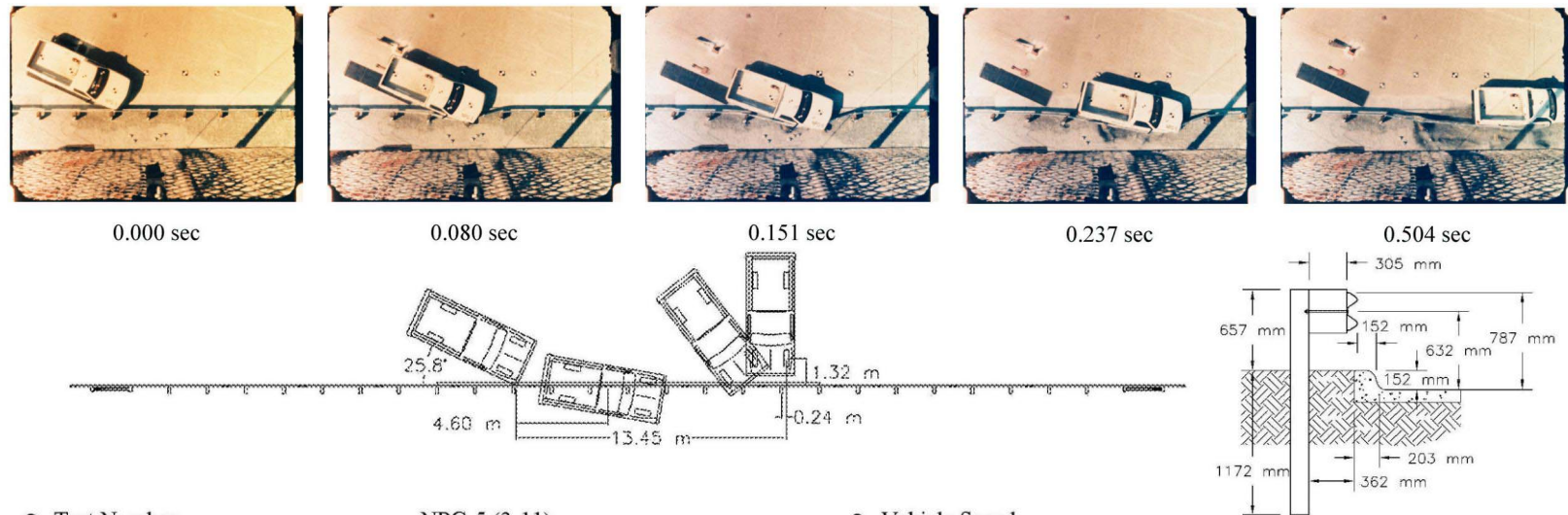

- Test Number NPG-5 (3-11)
- Date 9/4/02
- Appurtenance Midwest Guardrail System with curb
Key Elements increased mounting height and blockout
depth, midspan splices, and curb
- Total Length 55.25 m
- Steel W-beam
Thickness 2.66 mm
Top Mounting Height 787 mm
- Steel Posts
Post Nos. 3 - 27 W152 x 13.4 by 1,829-mm long
Spacing 1,905 mm
- Wood Posts
Post Nos. 1 -2, 28 - 29 (BCT) 140 mm x 190 mm by 1,080-mm long
- Wood Spacer Blocks
Post Nos. 3 - 27 152 mm x 305 mm by 356-mm long
- Curb 152-mm tall Type B mounted 152 mm
in front of guardrail face
- Soil Type Grading B - AASHTO M 147-65 (1990)
- Vehicle Model 1997 Chevrolet C2500 pickup truck
Curb 1,813 kg
Test Inertial 1,988 kg
Gross Static 1,988 kg
- Vehicle Speed
Impact 96.6 km/hr
Exit (resultant) 48.0 km/hr
- Vehicle Angle
Impact (trajectory) 25.8 deg
Exit (orientation) 6.7 deg
- Vehicle Stability Satisfactory
- Occupant Ridedown Deceleration (10 msec avg.)
Longitudinal 10.50 g's < 20 g's
Lateral (not required) 8.66 g's
- Occupant Impact Velocity
Longitudinal 5.23 m/s < 12 m/s
Lateral (not required) 3.93 m/s
- Vehicle Damage Moderate
TAD²⁶ 1-RFQ-4
SAE²⁷ 01RFEW5
- Vehicle Stopping Distance 13.45 m downstream
1.32 m left
- Test Article Damage Moderate
- Maximum Deflection
Permanent Set 611 mm
Dynamic 1,024 mm
- Working Width 1,625 mm

FIGURE 7 Summary of Test Results and Sequential Photographs, Test No. NPG-5 [1 in. = 25.4 mm].

(a)

Barrier VII Parameters	Input Values			
	Initial Run	NPG-4 Final Validation Run	NPG-6 Final Validation Run	Half Post Spacing Predictions
K_B - Post Stiffness Along B (strong axis) (kN/mm)	1.021	1.056	1.056	1.056
K_A - Post Stiffness Along A (weak axis) (kN/mm)	0.701	0.701	0.701	0.701
M_A - Moment About A (strong axis) (kN*mm)	18549	16230	16230	16230
M_B - Moment About B (weak axis) (kN*mm)	10494	10494	10494	10494
δ_F - Failure Displacement Along B (mm)	381	381	381	381
μ_k - Kinetic Friction Coefficient (Vehicle to Rail)	0.350	0.400	0.475	0.425
I_{m_z} - 2000P Mass Moment of Inertia - Yaw ($N*m*s^2$)	4971	5356	5356	5356

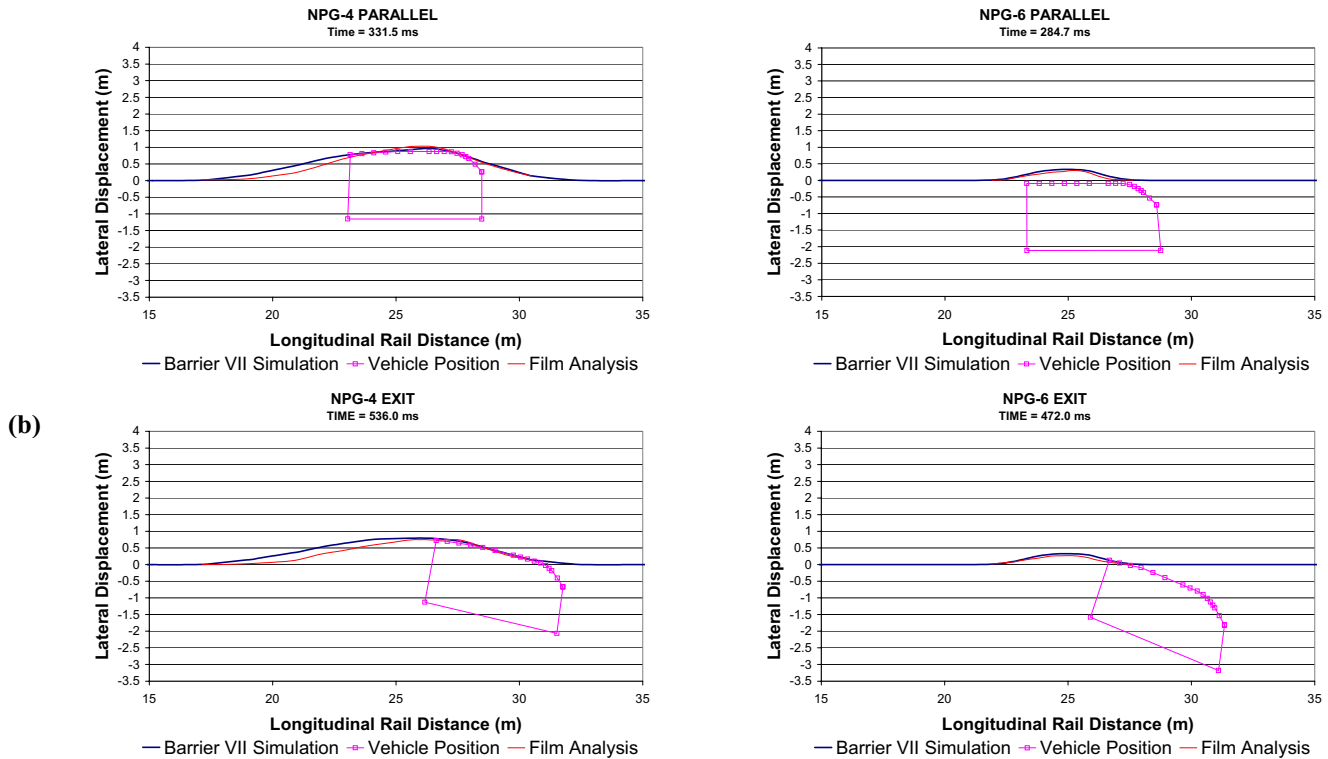

(c)

Evaluation Parameters	Results Comparison			
	1905-mm Post Spacing		476.25-mm Post Spacing	
	Test No. NPG-4	Simulation	Test No. NPG-6	Simulation
Parallel Time (ms)	396.4	331.5	296.8	284.7
Dynamic Rail Deflection (mm)	1094	1054	447	418
Working Width (mm)	1260	1391*	931	845
Working Width Indicator	Hood Corner	Post*	Post	Post
Exit Time (ms)	596.6	536.0	490.6	472.0
Exit Angle (degrees)	8.8	9.9	17.5	17.1
Exit Velocity Vector (degrees)	19.4	13.2	12.9	14.4
Resultant Velocity at Exit (km/hr)	55.1	56.26	59.5	50.44

*Although the post was the working width indicator, it is unlikely that the post would remain attached to the rail for that displacement. If the working width is governed by the engine/hood corner intrusion, the estimated working width would be 1235 mm.

FIGURE 8 Barrier VII Calibration and Validation: (a) Selected Simulation Input Parameters, (b) Graphical Comparison of Barrier Displacements, (c) Tabulated Results of Actual Test Data and Barrier VII Simulation [1 in. = 25.4 mm].

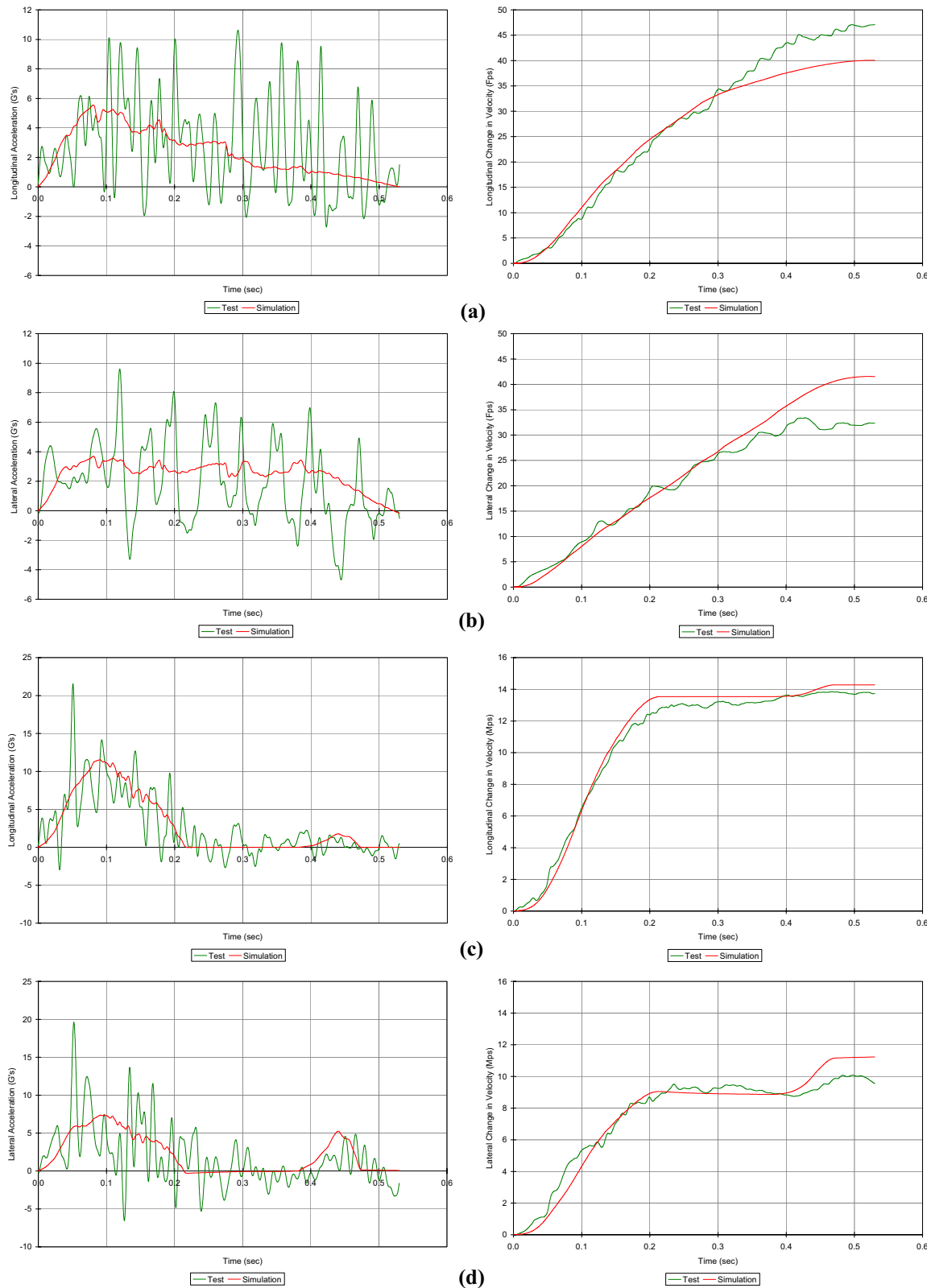

FIGURE 9 Comparison of Test and Simulation Results: (a) Longitudinal Direction [NPG-4], (b) Lateral Direction [NPG-4], (c) Longitudinal Direction [NPG-6], and (d) Lateral Direction [NPG-6] [1 in. = 25.4 mm].

LIST OF TABLES

TABLE 1 Steel Post Bogie Impact Test Matrix and Results [1 in. = 25.4 mm]

TABLE 1 Steel Post Bogie Test Matrix and Results [1 in. =25.4 mm]

Bogie Test No.	Impact Speed (m/s)	Embedment Depth (mm)	Initial Peak Force		Estimated Average Force ¹		Estimated Initial Stiffness ² (kN/mm)	Total Energy		Failure Mode
			Deflection (cm)	Force (kN)	Measured @ 381 mm dynamic deflection (kN)	Measured @ 597 mm dynamic deflection (kN)		Deflection (cm)	Energy (kJ)	
NPGB-1 ³	8.94	1092	6.12	47.91	28.98	30.63	0.783	104.53	29.82	Post Rotation, Slight Yielding
NPGB-3 ³	8.94	1092	5.29	43.00	25.57	26.35	0.813	124.17	28.45	Post Rotation, Slight Yielding
Average	8.9	1092	5.7	45.5	27.3	28.5	0.798	114.4	29.1	
NPGB-2 ³	9.39	1016	5.56	36.76	27.27	29.93	0.661	115.29	29.15	Post Rotation
NPGB-4	8.94	1016	5.56	52.83	28.73	29.30	0.950	109.23	29.14	Post Rotation
NPGB-9	9.28	1016	5.48	58.04	28.14	28.31	1.059	122.15	29.16	Post Rotation, Slight Yielding
NPGB-10	9.61	1016	5.97	62.89	29.99	31.47	1.053	118.56	31.78	Post Rotation, Slight Yielding
Average	9.3	1016	5.6	52.6	28.5	29.8	0.931	116.3	29.8	
NPGB-5	8.94	940	7.24	52.39	24.85	26.95	0.724	136.50	27.37	Post Pulled Out of Ground
NPGB-7	8.81	940	4.93	57.23	23.13	24.04	1.161	132.63	22.50	Post Pulled Out of Ground
NPGB-8	9.25	940	7.19	72.34	26.38	27.01	1.006	116.41	24.83	Post Pulled Out of Ground
Average	9.0	940	6.5	60.7	24.8	26.0	0.964	128.5	24.9	
NPGB-6	9.16	864	4.56	55.44	24.63	24.79	1.216	134.01	24.20	Post Pulled Out of Ground

1 – Determined after initial slope.

2 – Determined using initial peak force and deflection

3 – Results may have been effected by wet soil conditions